

SERVICE MANUAL

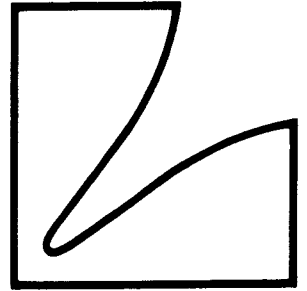

Stereo Integrated Amplifier

A-371

- This model comes in 2 colors (black and champagne gold).
Refer to this service manual for details.

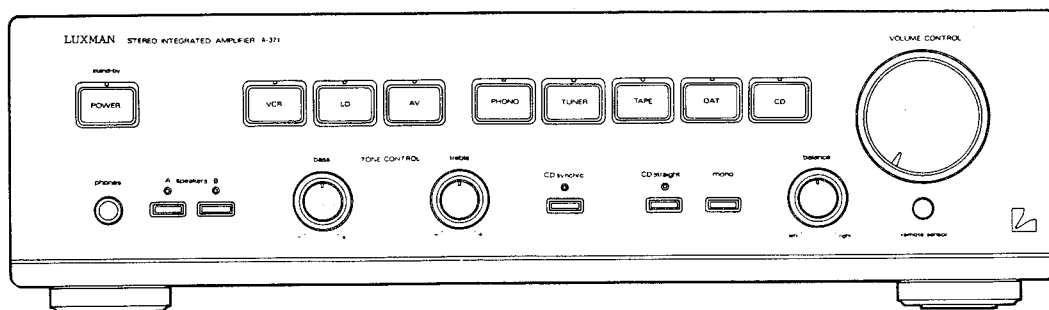

Contents

Specifications	3
Connection Guidelines	4 to 5
Names and Functions of Parts	6 to 8
Operation Guidelines	9 to 11
Disassembly Instruction	12 to 13
Adjustment Procedures	14
Adjustment Locations	15
Block Diagram	16
Parts Layout on P. C. Boards and Wiring Diagram	17 to 22
Schematic Diagram	23 to 30
Electrical Parts List	31 to 37
Cabinet Assembly Parts List	38
Exploded View (Cabinet)	39 to 40
Packing Assembly Parts List	41
Packing Method View	41
Semi-Conductor Lead Identifications	42 to 45
Spare Schematic Diagram Inserted.	

Specifications

Power Output (0.08% T.H.D, 8ohm, 20Hz~20kHz)	53W
Headphones Output (53W/8ohm, 1kHz)	600 ± 100mV
Input Sensitivity (Ref. 1kHz, 55W/8ohm)	Line: 160 ± 20mV Phone: 2.7 ± 0.3mV
Frequency Response	Line: - 13.73 ± 1dB Phone: 13.09 ± 1dB
Distortion (Ref. 1kHz)	0.05%
Tone Controls	Bass: (100Hz) ± 8 ± 2dB Treble: (10kHz) ± 8 ± 2dB
Cross Talk (Ref. 1kHz)	60dB
Residual Noise	1.5mV
Power Supply	AC 220/240V, 50Hz
Semiconductors	17 IC's, 54 Transistors, 40 Diodes, 3 Zener Diodes
Dimensions (W×H×D)	438 × 125 × 363 mm
Weight	9.5kg

NOTE: Due to continuing product improvement, specifications and designs are subject to change without notice.

Connection Guidelines

Before Making Connections

It is always wise to ensure that all AC power cords of the various components that you are interconnecting are unplugged from the wall outlets during the hook-up process. This will prevent any inadvertent damage to your speakers or amplifier from incorrect control settings or connections.

Interconnecting Leads

- Be sure that left and right channel identification is correct when making interconnections. Most patch cords are color coded with RED ends for the right channel and BLACK or WHITE ends for the left channel, to make this job easier.
- In addition, all jacks on the rear of the A-371 have red centers for right channel and white for left channel.
- When making connections, follow the reference illustrations on page 4, referring also to the descriptions for items 34 through 51 on page 11.

Turntable

1. A turntable has a pair of cords with a pin plug attached at each end. Connect these plugs to the "PHONO" input jacks on the A-371.
2. Connect the ground lead from the turntable to the "GND" terminal of the A-371.

Tuner

Connect the output jacks of a tuner to the "TUNER" input terminals of the A-371.

DAT or Tape Deck

1. Connect the line out jacks (left and right) of your DAT or tape deck to the "DAT/TAPE IN" jacks (left and right) of the A-371.
2. Connect the input jacks (left and right) of your DAT or tape deck to the "DAT/TAPE OUT" jacks (left and right) of the A-371.

CD Player

Connect the output jacks of a Compact Disc Player to the CD input jacks of the A-371.

Connection of Other Audio Sources

Connect the audio output of a VCR, Video Disc Player, CD Player, Cassette Deck, etc. to the "AV" input jacks of the A-371.

Speakers

The A-371 accepts two sets of 2-speaker systems (A and B). Connect at least one pair of speakers for stereophonic sound reproduction. Using heavy-gauge quality speaker cables (available at most hi-fi stores) but allowing the shortest possible length required, make connection between the right speaker to the right speaker terminals, the left speaker to the left speaker terminals. Make sure your first 2-speaker system is connected to the "speakers A" terminals on the A-371, matching left to left, right to right, (+) to (+), and (-) to (-), as the incorrect connections would result in improper phase and subdued low frequency response. Follow the steps above for connection of your second 2-speaker system, but this time to the "speakers B" terminals.

For Connection:

1. Cut away about 12 mm of insulating shield from the end of speaker cable and twist the exposed loose wires.
2. Flip the fastener on the speaker terminal up or down. Insert the twisted bare wires into the opening and close the fastener.

AC Power Cord

Plug into an AC power supply source. If any noise or static is noticed, unplug and plug in again reversing the polarities.

AC Outlets

For convenient AC power connection of other audio component in your system, 1 switched outlet (100 watts max.) is available.

On SYSTEM BUS

- This unit is an amplifier adaptable to the "SYSTEM BUS", and allows control from a remote control when used in combination with other modes adaptable to the "SYSTEM BUS".
- Models adaptable to the "SYSTEM BUS" have a mark .

Connection of the SYSTEM BUS

- Connect the "SYSTEM BUS" cables after disconnecting the power plug from the AC outlet.
- Connection of the "SYSTEM BUS" cables will be made in any order of connections and models.
- For normal position of the bus line jack, make sure each product and its owner's manual.
- Connect the power plug to a wall AC output or an unswitched outlet.

Note on the ADAPTER jacks

- Keep the jumper bars inserted when the "ADAPTER" jacks are not in use. If the jumper bars are removed, the sound will not be output.
- Remove the jumper bars only when connecting a graphic equalizer or surround amplifier to the "ADAPTER" jacks.

Names and Functions of Parts

Front Panel

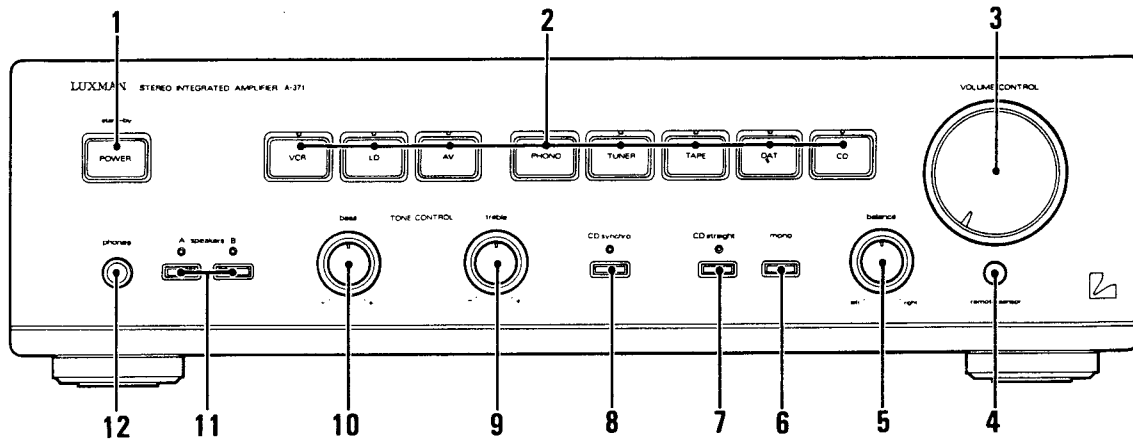

1. **“POWER” button and “stand-by” indicator**
For turning the power on and off for the whole system.
When the AC power cord is connected, this indicator light.
2. **Input select buttons and indicator**
Press the desired input select button: CD, DAT, TAPE, TUNER, PHONO, AV, LD, and VCR.
3. **“VOLUME CONTROL” and indicator**
Rotating the “VOLUME CONTROL” clockwise increases the volume.
Rotating the “VOLUME CONTROL” counterclockwise decreases the volume.
This indicator lights up when the “POWER” button (item #1) is turned on. The indicator blinks when the “VOLUME” button (item #19) or “MUTE” button (item #18) is operated.
4. **“remote sensor”**
5. **“balance” control**
Adjust for equal volume level between channels. Normally, with today’s high quality sources, it is seldom necessary to move this control from its precision center position.
6. **“mono” button**
Normally keep mono button released (stereo) for stereo mode.
Depress mono button (mono) for monaural mode to check the sound (phase), etc.
7. **“CD straight” button and indicator**
Press “CD straight” button to set the mode to CD straight.
8. **“CD synchro” button and indicator**
CD play and recording can be started simultaneously by simply pressing the “CD synchro” button.
9. **“treble” control**
This control will increase or decrease high frequency content in the program material. At the center detent position, a flat frequency response results.
10. **“bass” control**
This control will increase or decrease low frequency content in the program material. At the center detent position, a flat frequency response results.
11. **“speakers A and B” select buttons and indicators**
Two sets of stereo speakers systems may be used with the A-371; A and B buttons corresponding with A and B speaker terminals on the back panel (item #51). You may choose independent or simultaneous operation of the two systems by using these buttons.
12. **“phones” (headphones) jack**
Connection of stereophonic headphones to this jack allows private listening.

Remote Control Unit RA-371

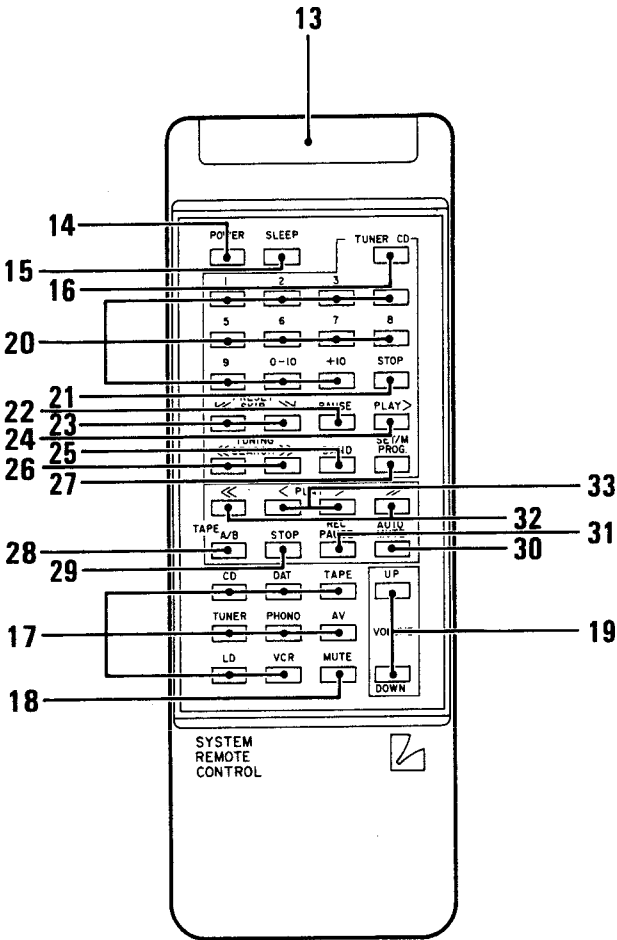

- 13. R/C signal transmission window
- 14. "POWER" button
- 15. "SLEEP" button
- 16. "TUNER/CD" selector
- 17. Input select buttons (CD, DAT, TAPE, TUNER, PHONO, AV, LD and VCR)
- 18. "MUTE" button
- 19. "VOLUME" buttons
- 20. Track select button
- 21. "STOP" button
- 22. "PAUSE" button
- 23. "PRESET SKIP" buttons (<< , >>)
- 24. "PLAY" button (>)
- 25. "BAND" button
- 26. "TUNING SEARCH" buttons (<< , >>)
- 27. "SET/M PRO." button
- 28. Deck "A/B" select button
- 29. "STOP" button
- 30. "AUTO MUTE" button
- 31. "REC PAUSE" button
- 32. Fast-forward/rewind buttons (<< , >>)
- 33. Playback/reverse playback buttons (< , >)

Note:

The buttons (item #15 and #20 to #33) can be operated only in case of the "SYSTEM BUS" connection.

Rear Panel

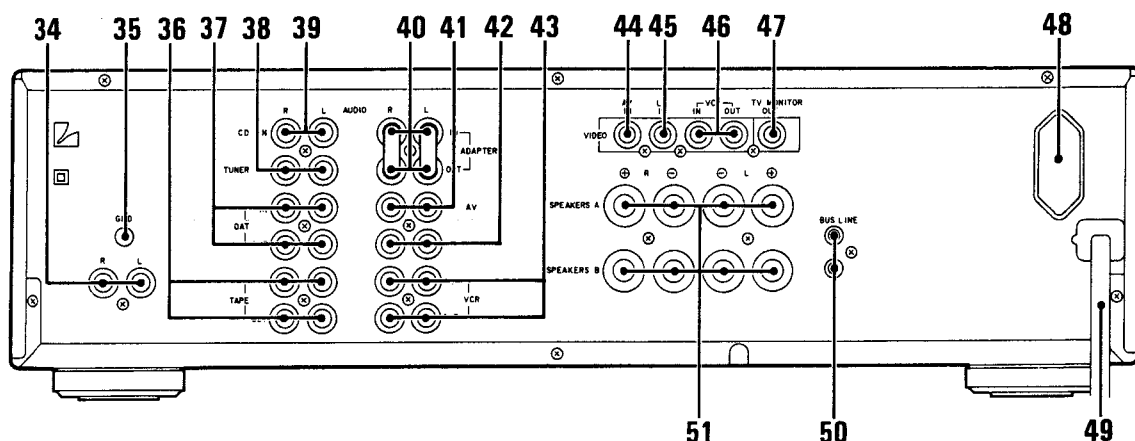
**34. "PHONO" jacks**

Accept the output from a turntable with an MM-, MI- or MC-type cartridge. The input sensitivity is 2.5mV, and the input impedance is 47k ohms. An MC type cartridge, of which the output is very low (0.01mV to 0.1mV), requires a step-up transformer or head amplifier to match the input sensitivity of the jacks on A-371.

35. "GND" terminal

Connect the ground wire of your turntable to this terminal.

36. "TAPE" jacks

Connect the LINE IN and LINE OUT jacks of your audio tape deck to these "TAPE OUT" and "IN" jacks respectively.

37. "DAT" jacks

Connect the LINE IN and LINE OUT jacks of your DAT to these "DAT OUT" and "IN" jacks respectively.

38. "TUNER" jacks

These input jacks are for connection to the output jacks of your tuner.

39. "CD" jacks

This set of jacks is for connection of a compact disc (CD) player. They may also be used for any other high level signal source.

40. "ADAPTER" jacks**41. "AV" jacks (AUDIO)****42. "LD" jacks (AUDIO)**

Connect a Laser Disc Player to these input jacks for playback purposes only.

43. "VCR" jacks (AUDIO)

Connect the LINE IN and LINE OUT jacks of your VCR to these "VCR OUT" and "IN" jacks respectively.

44. "AV" jack (VIDEO)**45. "LD" jack (VIDEO)**

Connect the VIDEO OUT jacks of your Laser disc player to the "LD IN" jack.

46. "VCR" jack (VIDEO)

Connect the VIDEO IN and VIDEO OUT Jacks of your VCR to these "VCR OUT" and "IN" jacks respectively.

47. "TV MONITOR OUT" jack

Connect this TV monitor jack to the input jack of a TV monitor.

48. AC outlet**49. AC Power Cord**

Connect the AC plug of the AC Power Cord into an AC household power outlet.

50. "BUS LINE" jacks**51. "SPEAKERS A & B" terminals**

You may connect 2 pairs of stereo speaker systems to these terminals of the A-371 to the corresponding red (+) and BLACK (—) terminals of your speakers on each channel.

The speaker systems may be switched on and off by the front panel "speakers A and B" buttons (item #11).

Operation Guidelines

The following procedures assume that all connections have been made according to the "Reference Illustrations".

Power and Source Switching

To prevent the possibility of excessive, sudden sound levels, it is recommended that the volume control be placed at a low level position each time the power button is turned on or when switching between source.

CD Player

1. Press the "CD" input select button (item #2).
2. Operate the CD player.

Tuner

1. Press the "TUNER" input select button (item #2).
2. Tune in the desired broadcast station.

Record Player

1. Press the "PHONO" input select button (item #2).
2. Operate the Record player.

DAT/Tape Deck Playback

1. Press the desired "DAT/TAPE" input selector button (item #2).
2. Operate the DAT or tape deck.

DAT/Tape Deck Recording

Press the input select button for recording from the program source. The program source signal is then sent to "DAT OUT" jacks (item #37) or "TAPE OUT" jacks (item #36) at the rear. Simultaneous recording is thus possible on the two decks.

How to copy from DAT to TAPE Deck

1. Press the "DAT" input selector button (item #2).
2. Load a prerecorded tape to the DAT and make preparation for playback.
3. Load a tape to be recorded to the TAPE deck and make preparation for recording.
4. Start the DAT and the TAPE decks.
 - When copying from the TAPE deck to the DAT, perform operations in the same way as shown above, except that "DAT" is replaced with "TAPE deck" and "TAPE deck" with "DAT".

Playback of Equipment Connected to the AV Jacks

1. Press the "AV" input select button (item #2).
2. Operate the unit connected to the "AV" jacks.

When the "SYSTEM BUS" cables are connected, following operations can be made.

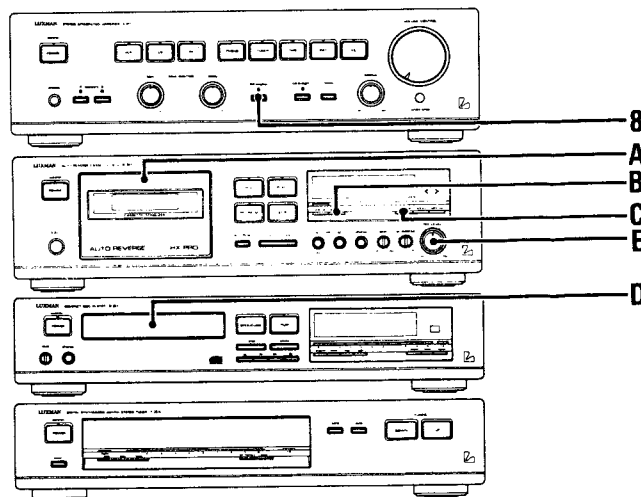

Automatic Switching of Music Sources

When an amplifier, tuner, and deck are connected to the "SYSTEM BUS", input selector (item #2) can be automatically switched from each equipment.

CD Synchronized Recording

When an amplifier, CD, and a cassette deck is connected to the "SYSTEM BUS", CD synchronized recording can be made.

CD play and recording can be started simultaneously by simply pressing the "CD synchro" button (item #8).

1. Insert a tape for recording into deck (item #A).
2. Select the reverse mode by pressing the reverse mode select button (item #B), if the unit has a reverse function.
3. Select the Dolby NR mode by pressing the "DOLBY NR" switch (item #C).

	DOLBY NR ON/OFF button	B/C button
To record in Dolby B NR mode	■ ON (depressed)	■ B (released)
To record in Dolby C NR mode	■ ON (depressed)	■ C (depressed)
To record without Dolby NR mode	■ OFF (released)	Any position

4. Place the disc in the CD player (item #D).
Recording will be made in any order of programs to length of the tape used, if your CD player has an editing function. For further details, refer to the manual of the CD player.
5. Turn "REC LEVEL" control (item #E) to rec adjust the recording level. (Normally set to the center position.)
6. Press "CD synchro" button (item #8) of the A-371. CD play and recording start simultaneously. The recording level is indicated in the level indicator. When +3 light up, the level is set appropriately.
7. To stop the synchronized recording, press the STOP button on the cassette deck or CD player.

Notes:

- Recording on both sides starts with the front side. Recording cannot be continued from the reverse side to the front side. Therefore, when the recording on the reverse side is completed, it stops.

- Recording is not performed if the playback button of the opposite direction is pressed.
- During recording, playback on deck A cannot be performed. (Rewinding and fast forwarding are possible.)
- Be sure to pass through the leader tape before recording. Otherwise, the beginning of the CD may not be recorded.
- Location of the switches will be different depending upon the models connected, so perform operations by referring to the Owner's Manual for each model.

Products connected to the "SYSTEM BUS" allow following operations from the "RA-371" remote control unit.

How to Use Sleep Timer

When the tuner is connected to the system control, timer operations are available. The power can be cut off automatically after 90-10 minutes. Setting step is 10 minutes.

1. Push the "SLEEP" button (item #15) during playback.
2. Set a desired time by repeatedly pushing the "SLEEP" button. The time will be changed by 10 minutes step each time the button is pushed.

With the tuner used, various timer playback can be made. For further details, refer to the manual for the tuner.

Turning on or off the power of the whole system

Press "POWER" button. (Item #14)

Operating the A-371 amplifier

- To select the desired source, press the button (item #17) for the desired source among CD, DAT, TAPE, TUNER, PHONO, AV, LD and VCR.
- To turn up the volume, press "VOLUME UP" button (item #19).
- To turn down the volume, press "VOLUME DOWN" button (item #19).
- To mute the sound temporarily, press "MUTE" button (item #18).
- To restore the sound, press it again. (During muting, the volume indicator blinks.)

Operating the cassette deck

		Item #
To start playback	>	33
To start reverse playback	<	33
To fast-forward to the right/rewind to the right	>>	32
To fast-forward to the left/rewind to the left	<<	32
To search to the right	>>	32
To search to the left • Each time the >> or << button is pressed, a track is detected. (Up to 8 tracks in both directions.)	> or < ↓ <<	33 32
To select deck A or B	A/B	28
To stop playback or recording	STOP	29
To set the cassette deck to recording pause mode	REC PAUSE	31
To record • Press < or >, whose direction is the same as that indicated by the tape direction indicator.	REC PAUSE ↓ < or >	31 33
To insert a 4-second blank and set the cassette deck in recording pause mode	AUTO MUTE	30

TUNER/CD selector

The same buttons of the RA-371 are used for operating the tuner and CD player. To operate the CD player, set this selector to CD. To operate the tuner, set this selector to TUNER.

Operating the tuner

Tuning in a station

- 1) Set "TUNER/CD" selector (item #16) to TUNER.
- 2) Press "BAND" button to select FM or AM (MW/LW).
- 3) Press << or >> to tune in a station.

Presetting the stations

- 1) Tune in a station following "Tuning in a station" above.
- 2) Press "SET/M PRO." button
- 3) Select a preset number with the "1"- "0-10" and "+10" buttons. (See the Owner's Manual of the TUNER for details.)

Receiving a preset station

Call up the preset number with the "1"- "0-10" and "+10" buttons. Or press << or >> to call up the preset stations in order.

Operating the D-351 CD player

- 1) Set "TUNER/CD" selector to CD.
- 2)

		Item #
To open the disc tray	STOP	21
To start play	PLAY	24
To stop play	STOP	21
To stop play temporarily	PAUSE	22
To skip tracks in forward direction	>>	23
To skip tracks in backward direction	<<	23
To search a track in forward direction	>>	26
To search a track in backward direction	<<	26

To play the desired track, press the track number with the "1"- "0-10" and "+10" buttons.

Programming tracks

- 1) Close the disc tray with "STOP".
- 2) Press "SET/M PRO." button.
- 3) Select tracks with the "1"- "0-10" and "+10" buttons in the desired order.
- 4) Press > .
(See the Owner's Manual of the CD player for details.)

Remote Operations

For reliable operation, use the hand-held remote control within the basic dimensional area.

Disassembly Instruction

1. Removal of Front Panel

- (1) After removal of the top cover, remove eight screws marked "O" as shown in Figures 1 and 2.
- (2) Disconnect all connectors from Control, Tone and Volume (1) P.C. Boards.
- (3) Front Panel with Display, Control, Tone, Volume (1)/(2), Speaker Switch, Remote Sensor and Phone P.C. Boards can be removed completely.

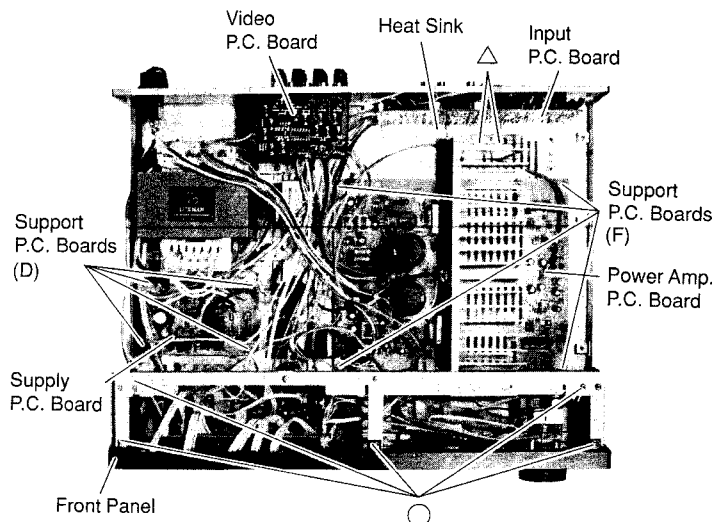

Figure 1

2. Removal of Control P.C. Board

- (1) After removal of Front Panel, remove three Hooks (A) as shown in Figure 3.
- (2) Disconnect all connectors from the P.C. Board.

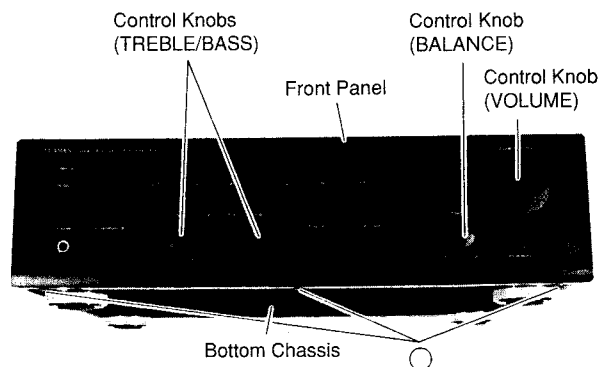

Figure 2

3. Removal of Volume P.C. Board (1)

- (1) After removal of Front Panel, remove a Control Knob (BALANCE) as shown in Figure 2.
- (2) Remove a Nut (B) as shown in Figure 4.
- (3) Remove two screws marked "x" as shown in Figure 3.
- (4) Disconnect two connectors from the P.C. Board.

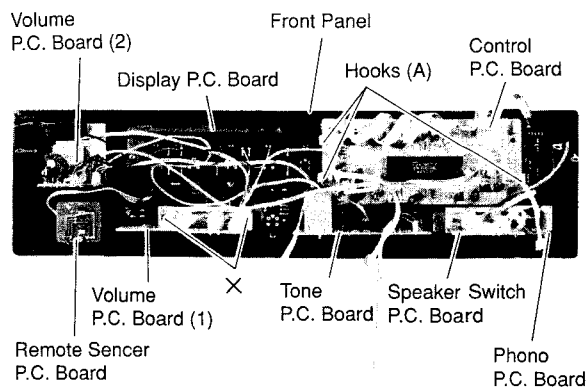

Figure 3

4. Removal of Volume P.C.Board (2)

- (1) After removal of Front Panel, remove a Control Knob (VOLUME) as shown in Figure 2.
- (2) Remove two screws marked "※" as shown in Figure 4.
- (3) Disconnect all connectors from the P.C.Board.

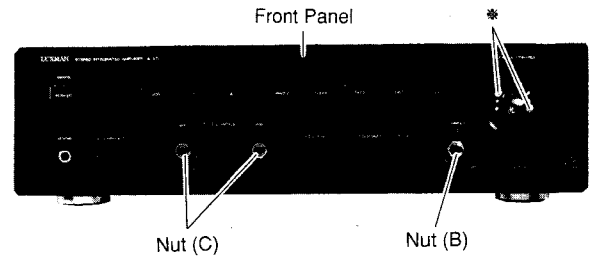

Figure 4

5. Removal of Tone P.C.Board

- (1) After removal of Front Panel, remove two Control Knobs (TREBLE / BASS) as shown in Figure 2.
- (2) Remove two Nuts (C) as shown in Figure 4.
- (3) Disconnect all connectors from the P.C.Board.

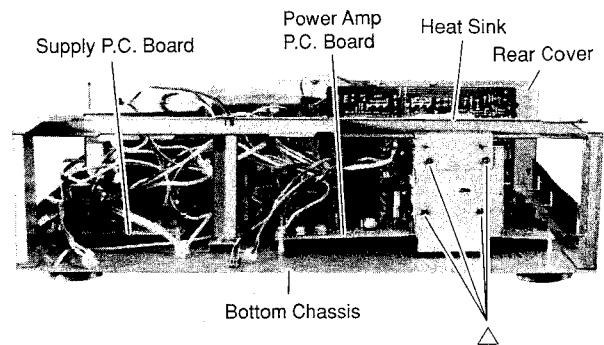

Figure 5

6. Removal of Supply P.C.Board

- (1) After removal of the top cover, remove four Support P.C.Boards (D) as shown in Figure 1, by pushing the point "E" as shown in Figure 6.
- (2) Disconnect all wires from the P.C.Board.

7. Removal of Power Amp P.C. Board

- (1) After removal of Front Panel, remove six screws marked "Δ" as shown in Figures 1 and 5.
- (2) Remove four Support P.C.Boards (F) as shown in Figure 1, by pushing the point "E" as shown in Figure 6.
- (3) Disconnect all wires from the P.C.Board.
- (4) Power Amp P.C.Board with Heat Sink can be removed completely.

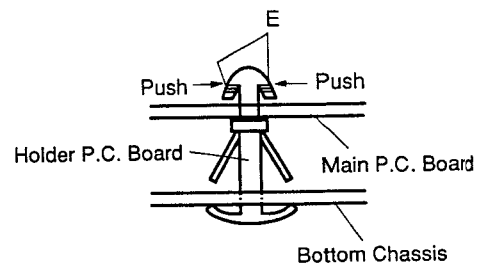

Figure 6

Adjustment Procedures

1. Connection

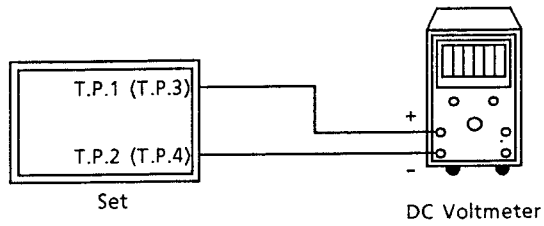

Figure 7

2. Control Settings

Power Switch ON
 Others OFF

3. Adjustment Procedures

● Idling adjustment

- (1) Set VR401 (sound volume) to its minimum.
- (2) Adjust VR701 (VR702) so that the voltage between T.P.1 (T.P.3) and T.P.2 (T.P.4) is 10mV.

Note: Wait about 3 minutes after turning ON the power to make the above adjustment.

Adjustment Locations

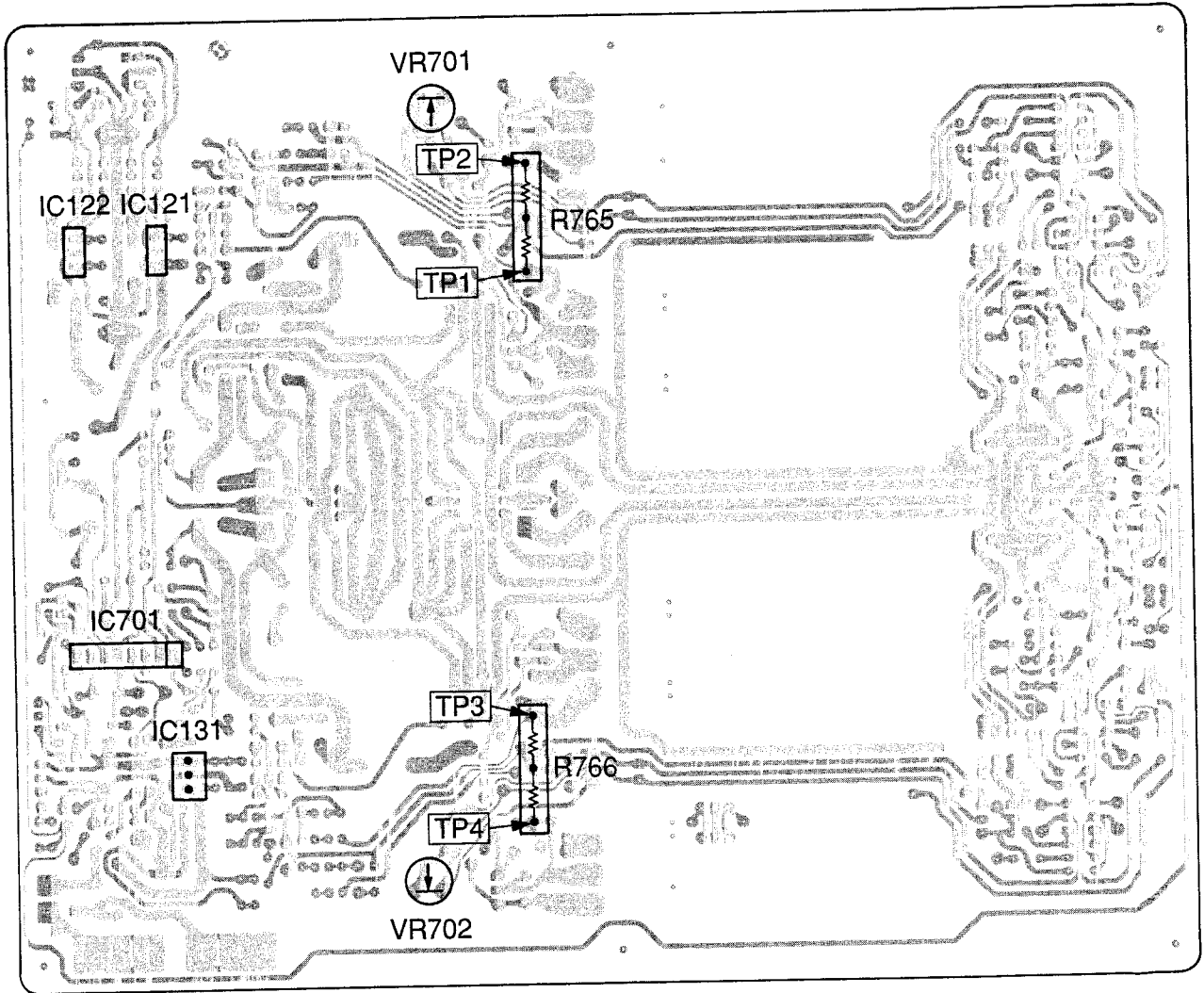

POWER AMP P.C. Board (Top View)

Block Diagram

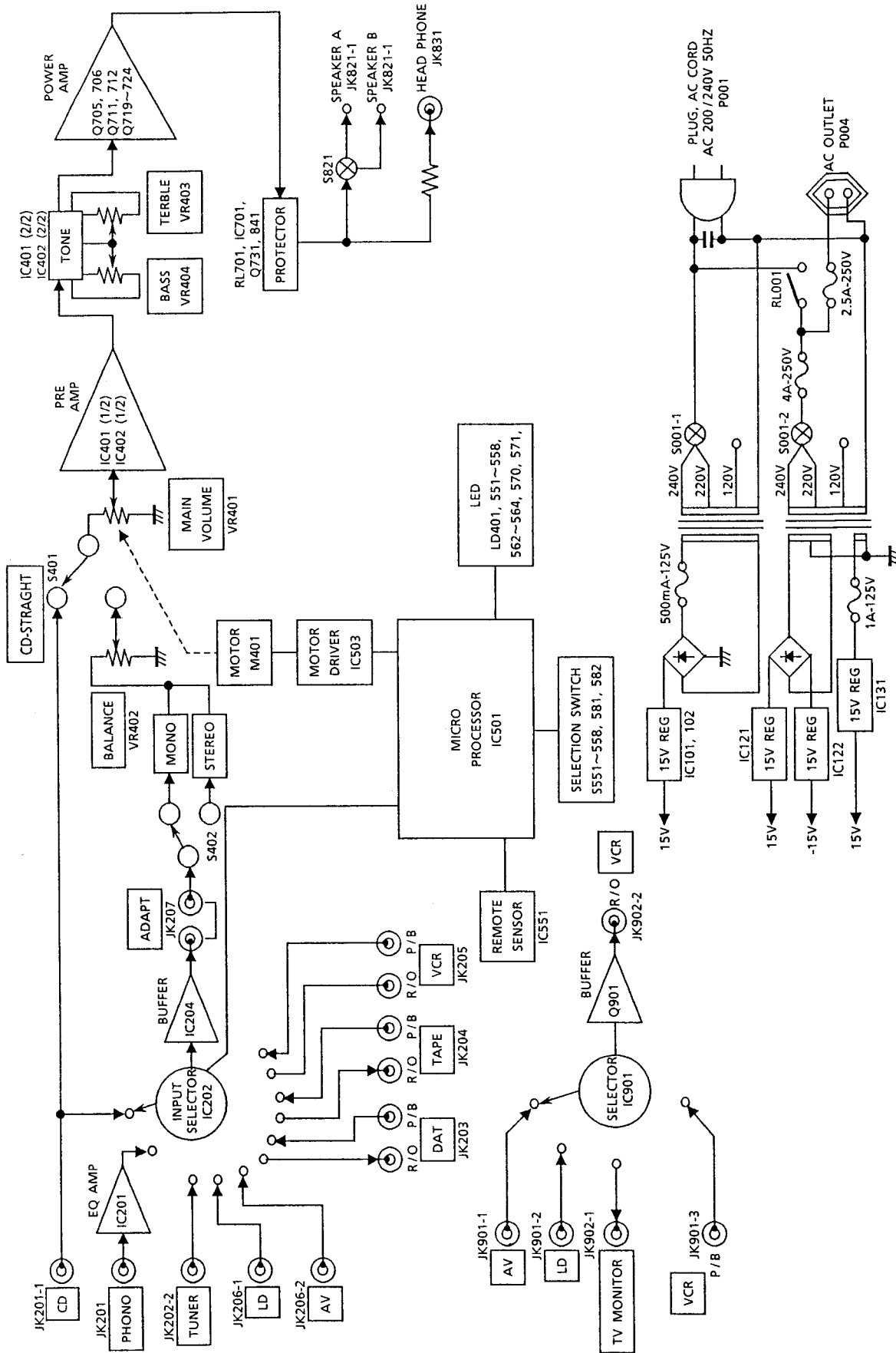

Parts Layout on P.C. Boards and Wiring Diagram (1/2)

All P.C. Boards viewed from foil side.

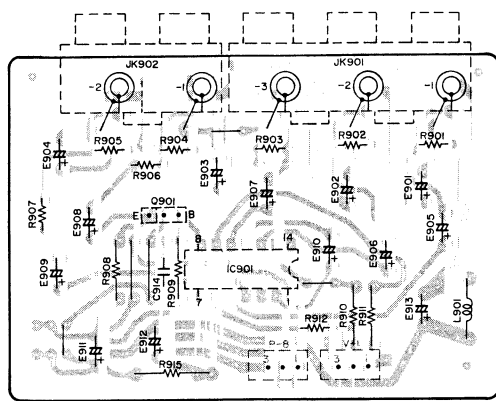

VIDEO P.C. BOARD

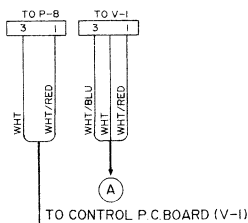

POWER AMP P.C. BOARD

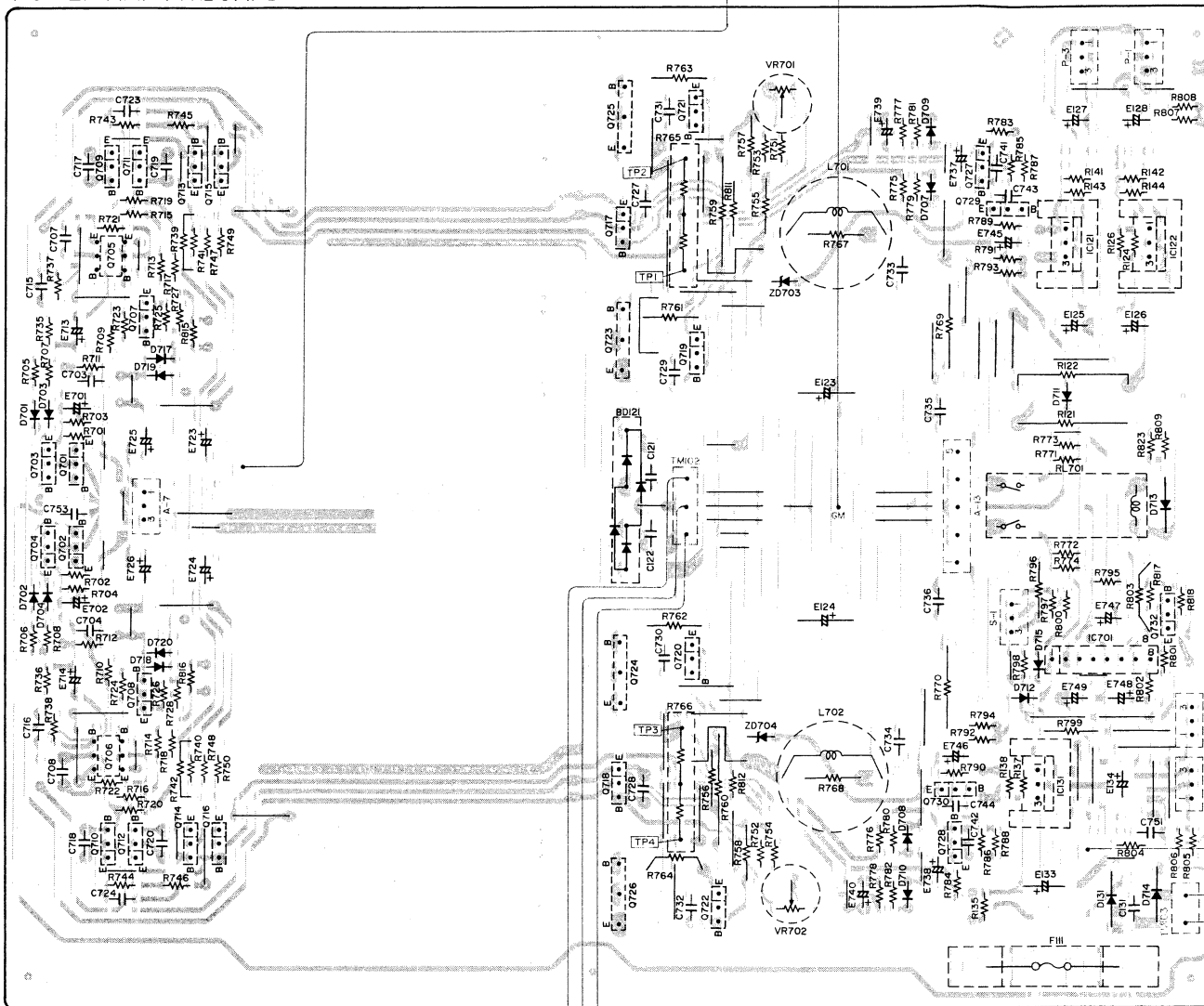

TONE P.C. BOARD

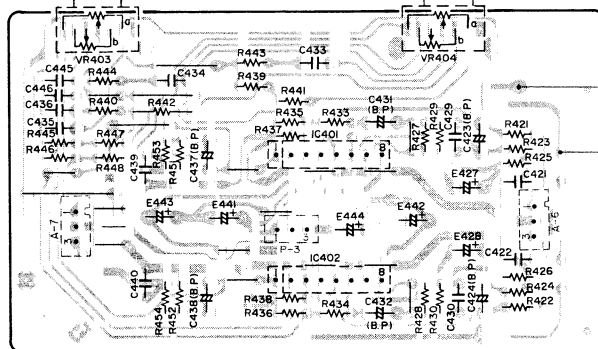

TRANSISTOR P.C. BOARD

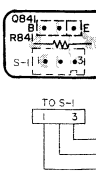

PHONE P.C. BOARD

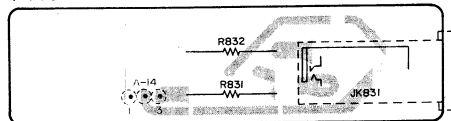

SPEAKER SWITCH P.C. BOARD

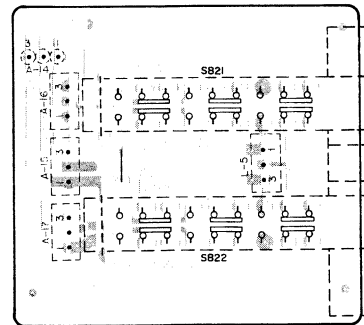

TO TERMINAL P.C. BOARD

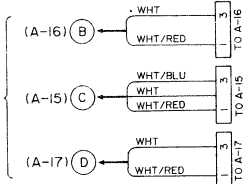

TO DISPLAY P.C. BOARD (L-5)



TO INPUT P.C. BOARD

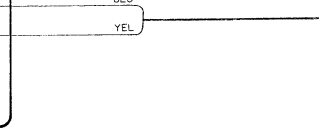
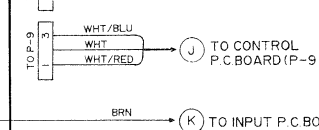
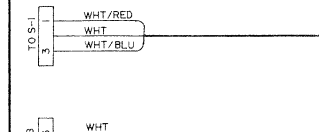
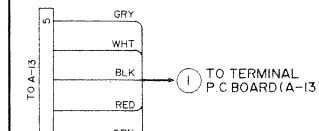
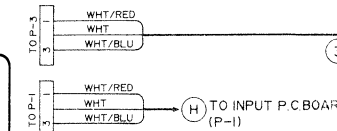
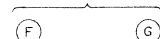

TO VOLUME P.C. BOARD (1)

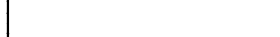

TO VOLUME P.C. BOARD (2) (A-6)



A

B

C

D

E

F

G

H

Parts Layout on P.C. Boards and Wiring Diagram (2/2)

All P.C. Boards viewed from foil side.

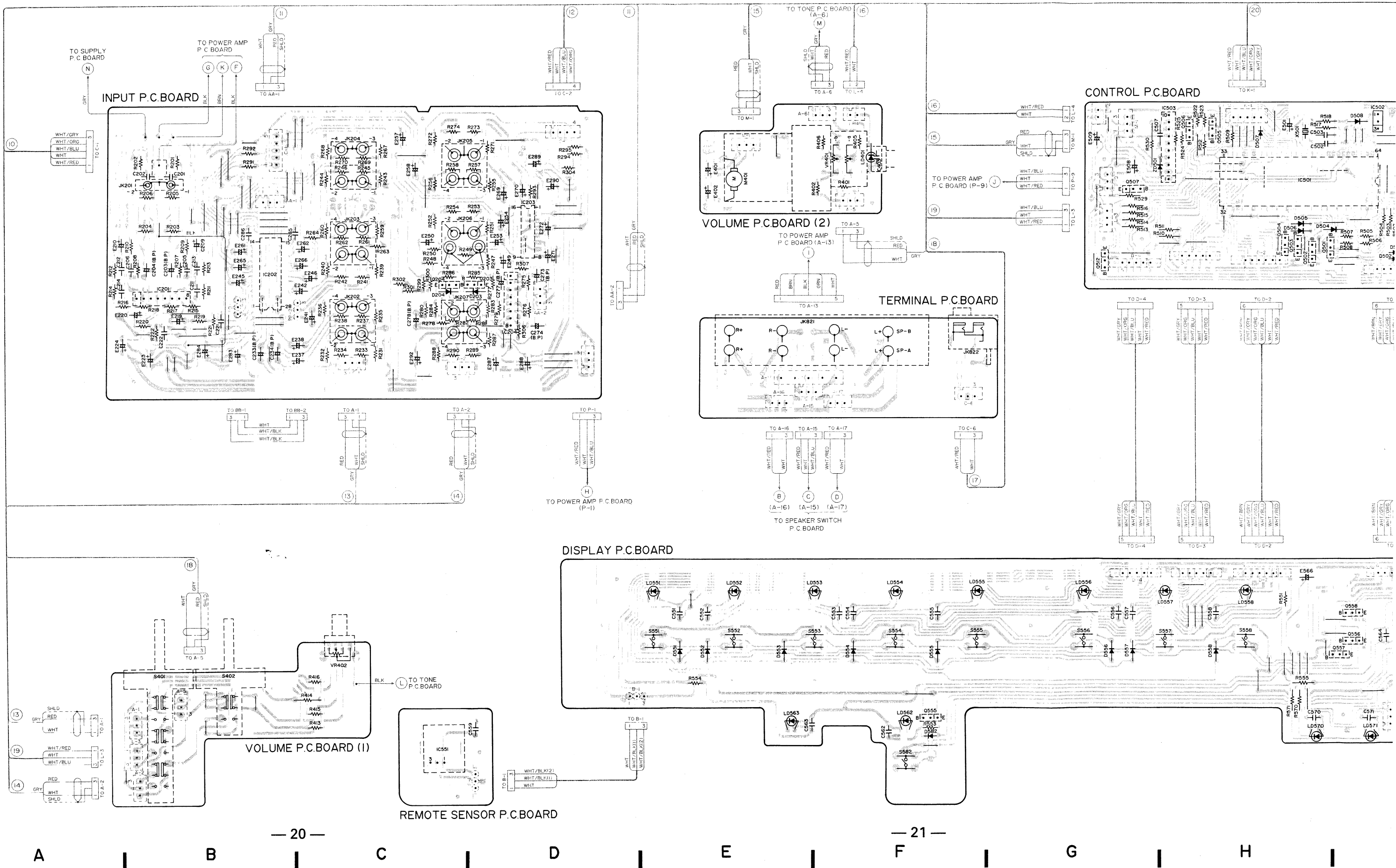

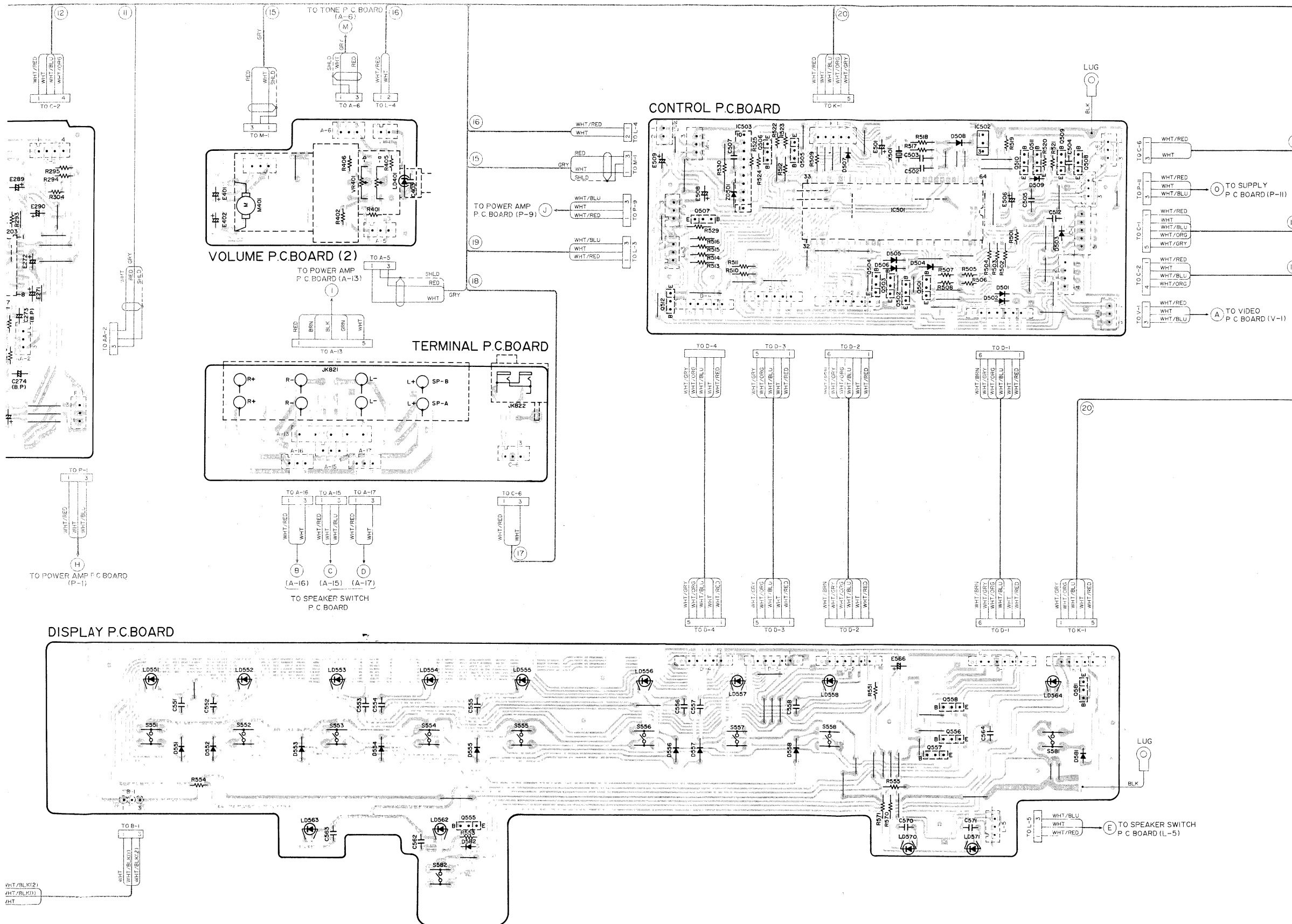

Schematic Diagram (1/2)

IC'S	IC201	IC202	IC203	IC204	IC401-A	IC402-A	IC901
TRANSISTORS (Q)	Q203 Q204						Q901

1
2
3
4
5

Input P.C. Board

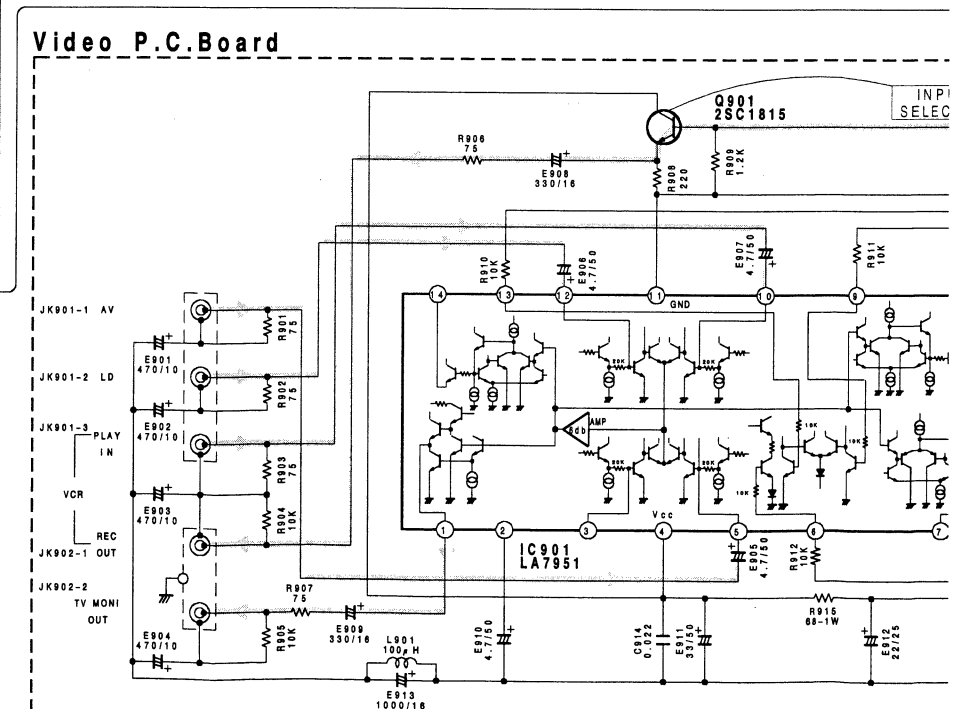
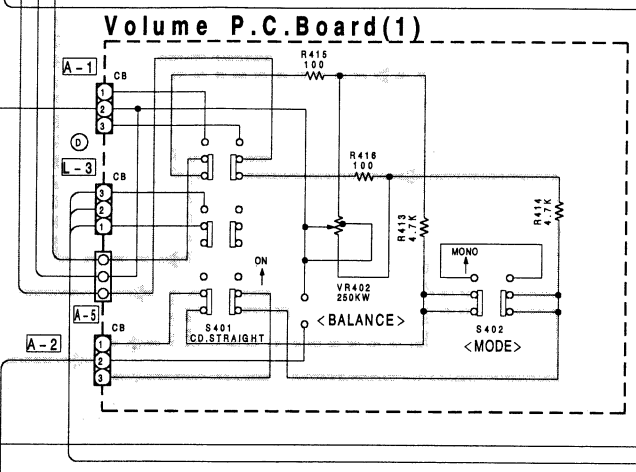
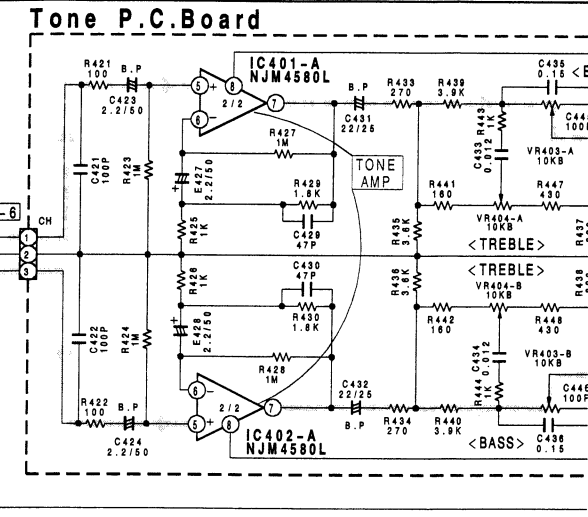
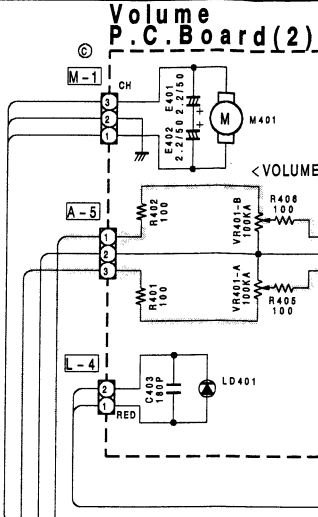
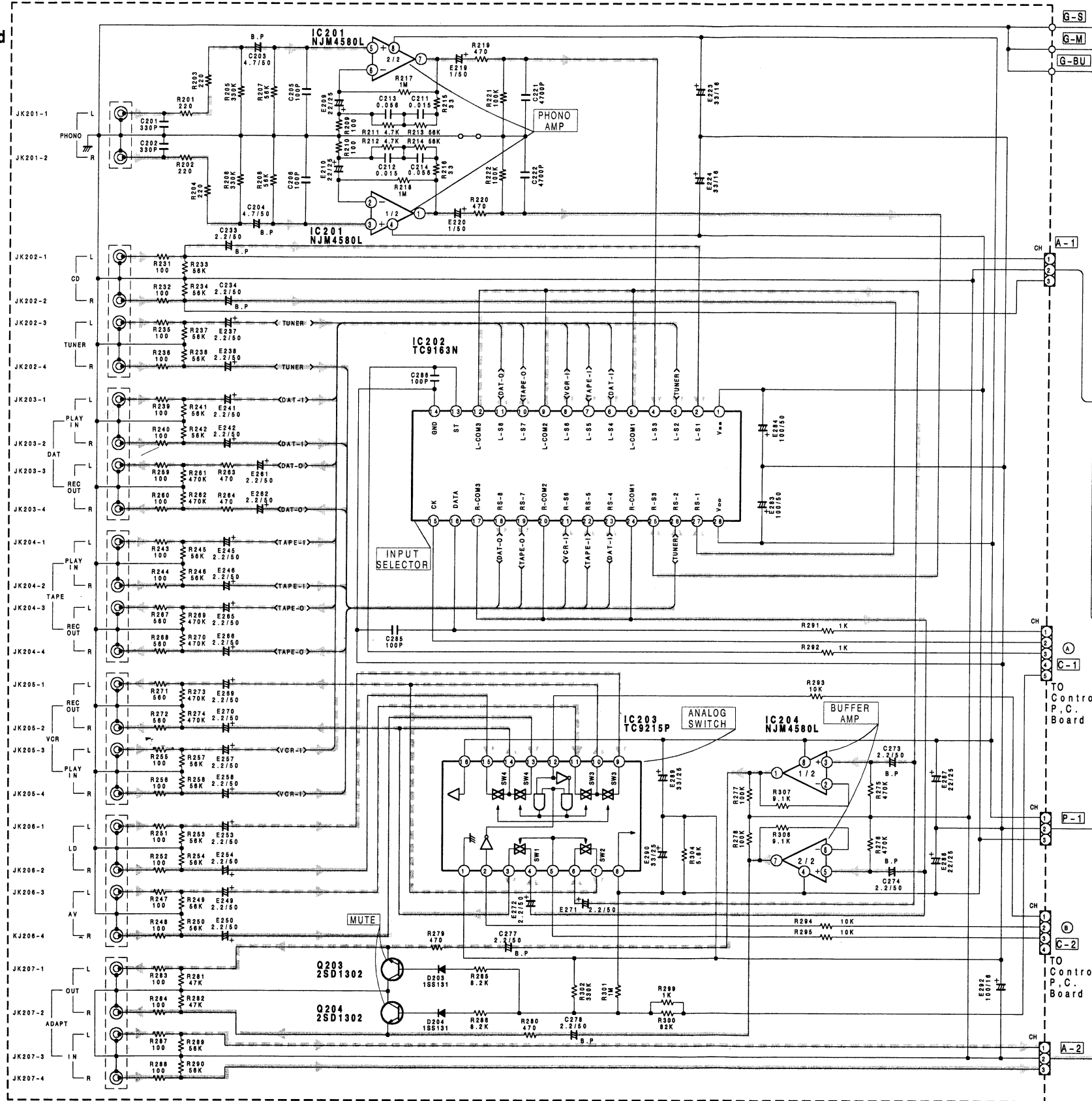

A | B | C | D | E | F | G | H

IC401-A IC402-A IC901	IC401-B IC402-B	IC121 IC122	IC131	IC701
Q901	Q703 Q701 Q702 Q704 Q706	Q705 Q707 Q708	Q709 Q713 Q710 Q714 Q712 Q716 Q718	Q719 Q721 Q722 Q720 Q723 Q725 Q724 Q728 Q727 Q728 Q730
				Q732 Q841

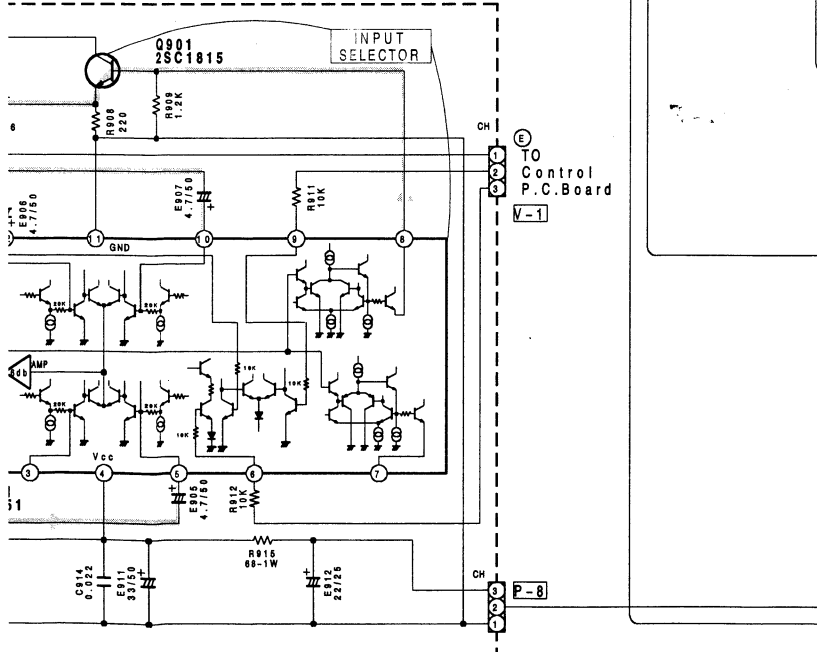
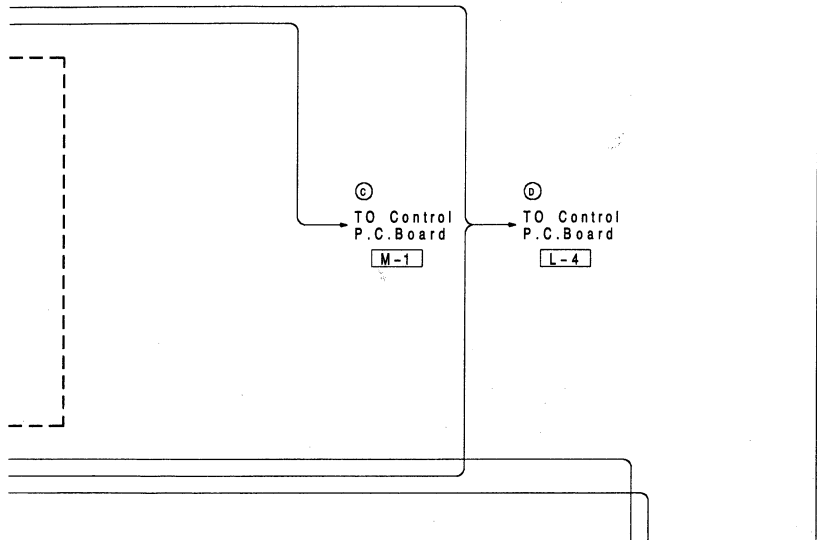
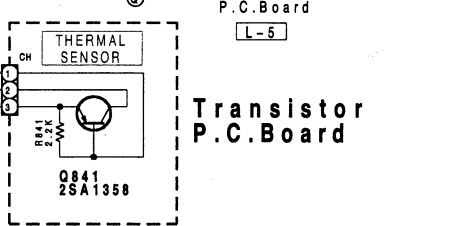
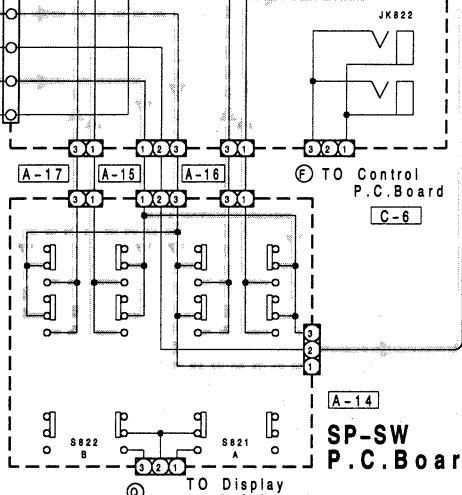
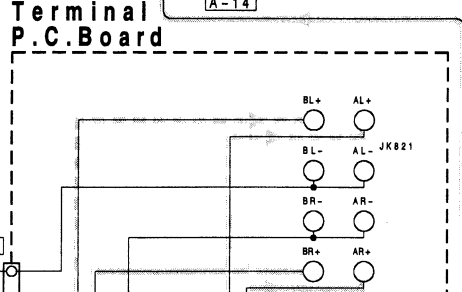
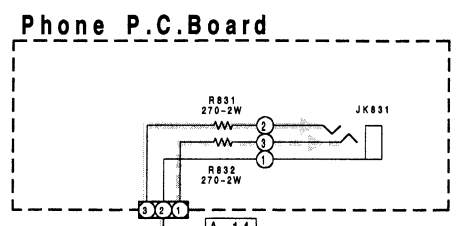
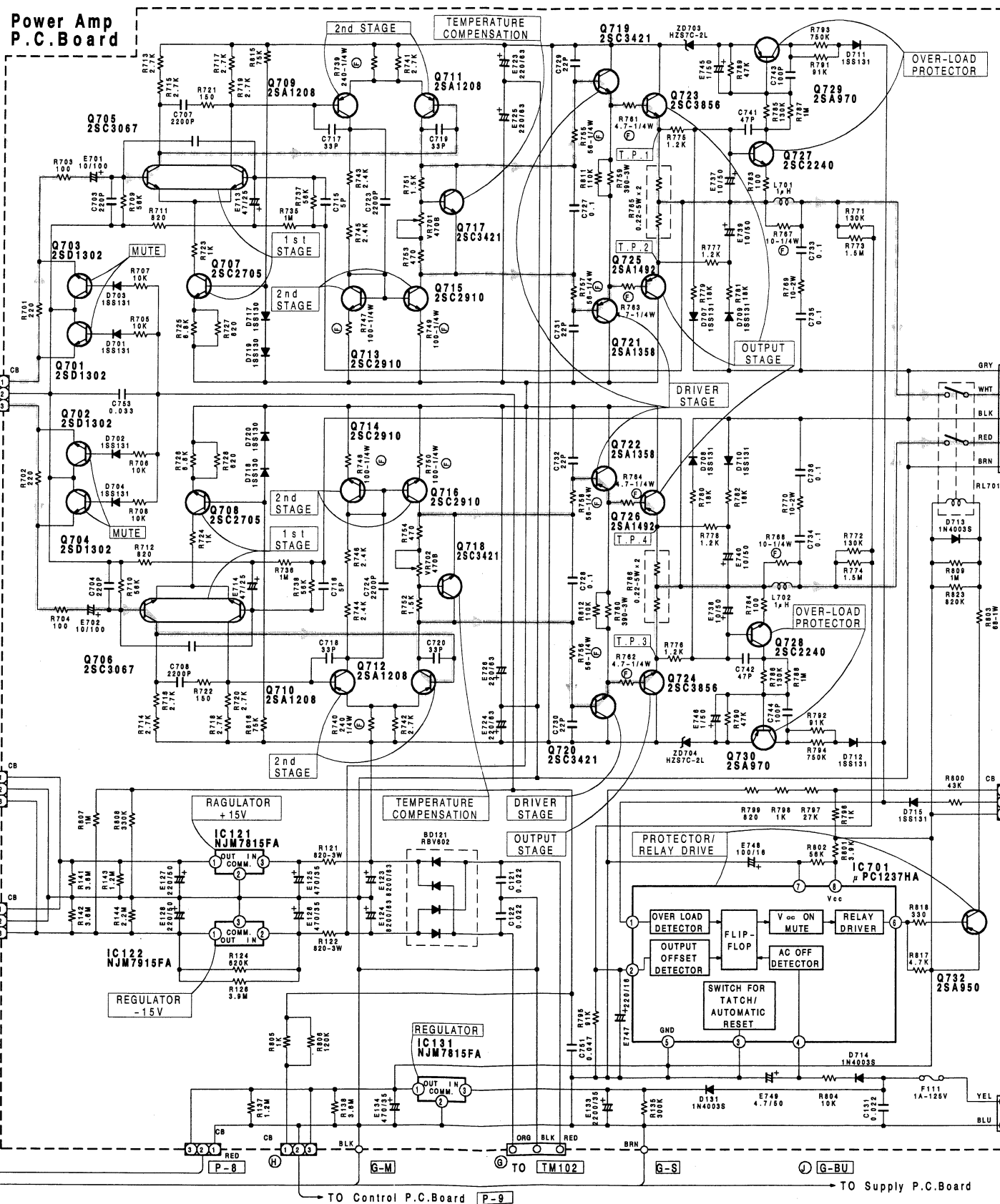
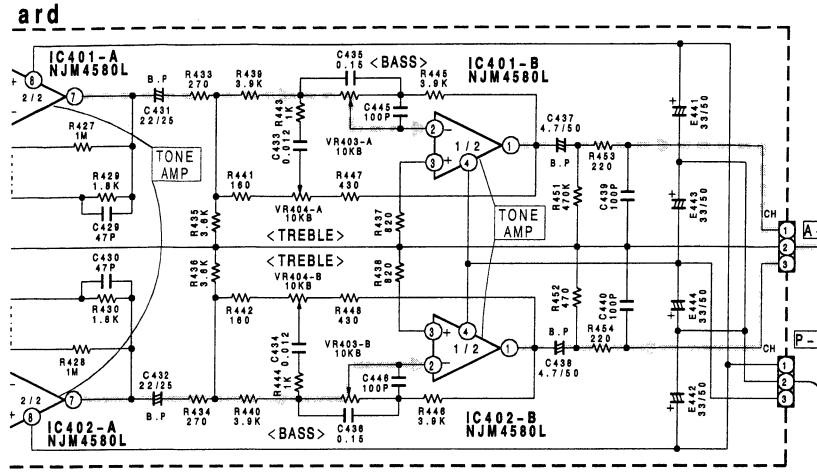

I | H | I | J | K | L | M | N | O

Schematic Diagram (2/2)

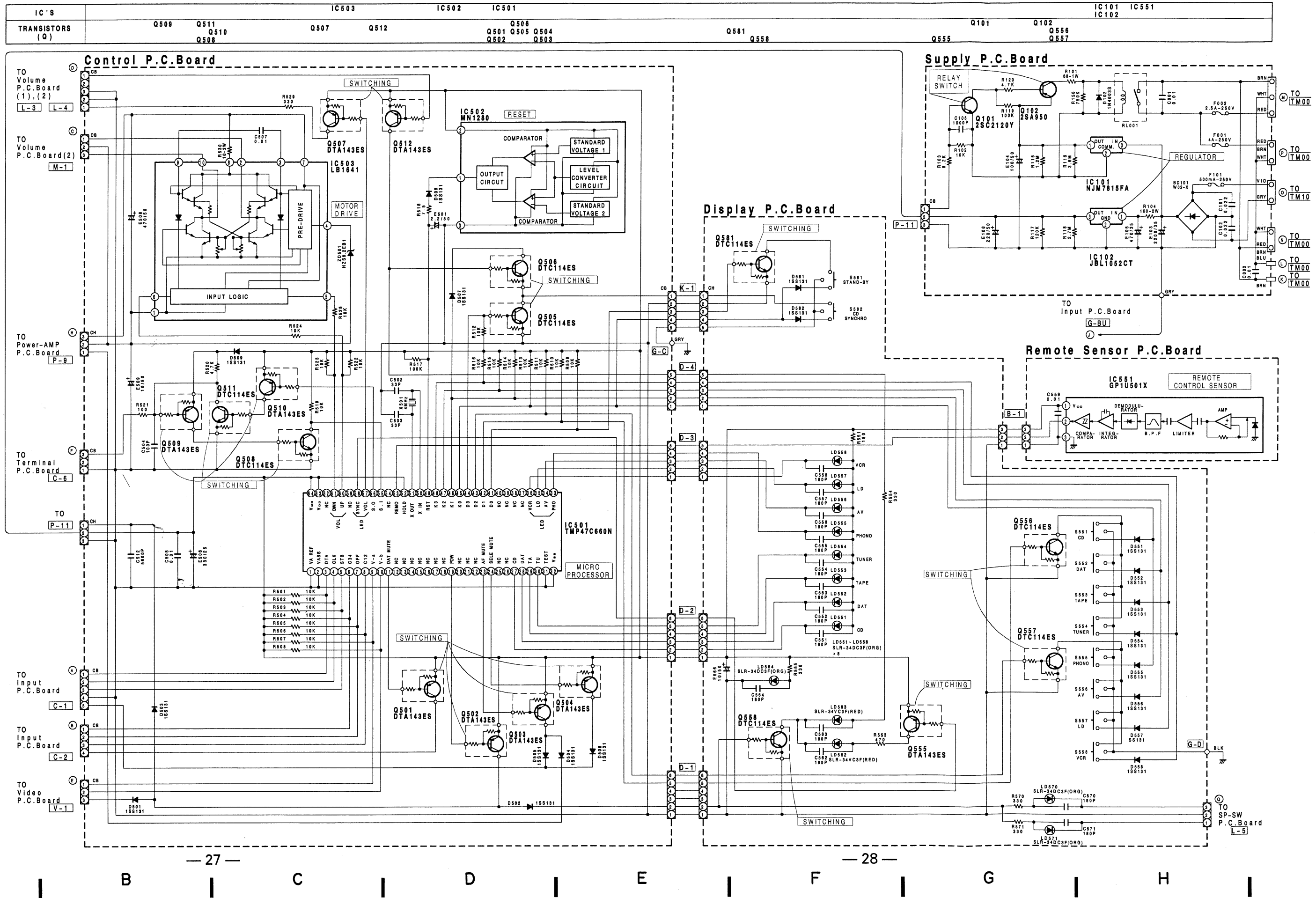

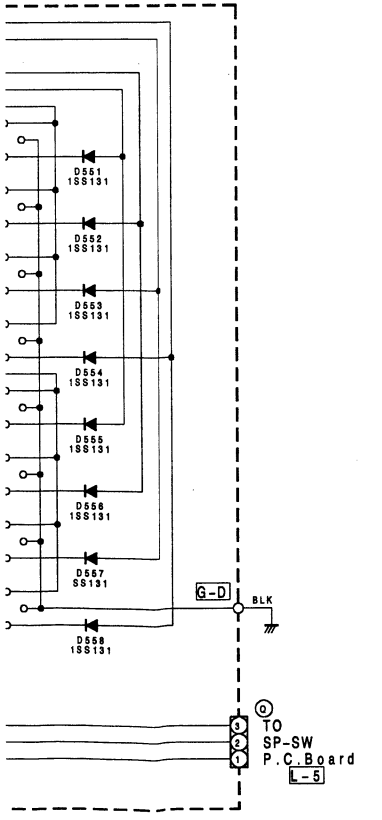
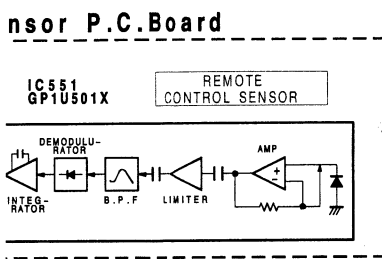
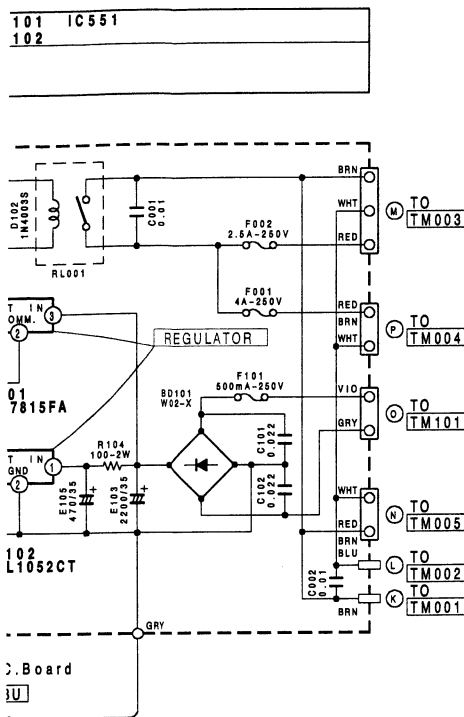

NOTE
 1.All resistance values are in ohms. K=1,000 M=1,000,000
 2.All capacitance values are in microfarads. P= 1/1,000,000

Voltage Measuring Conditions
 1.Power Supply Voltage :AC220/240V,50Hz
 2.Measuring Meter :Digital Multimeter
 3.Measuring Point Reference :Between Ground
 4.Measuring Conditions :No Signal Input,Power Switch 'ON'

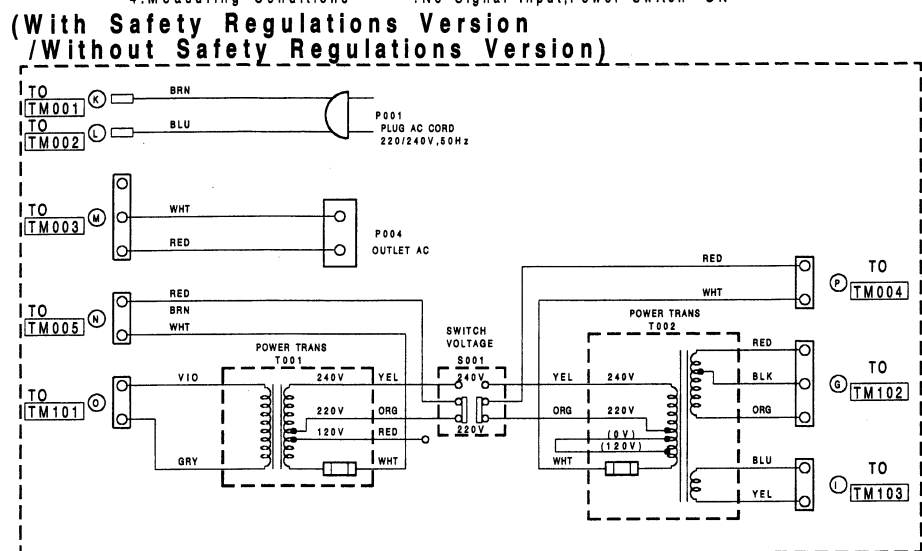

IC101	IC102	IC121	IC122	IC131	IC502	IC551
1 15.1V	4.9V	15.1V	-15.1V	15V	5V	0V
2 0V	0V	0V	-23.3V	0V	5.1V	4.8V
3 20.1V	12.6V	23.1V	0V	21.8V	50mV	4.9V

IC201	IC204	IC401	IC402	IC701
1 -150mV	70mV	0V	-1mV	13mV
2 3mV	72mV	-1mV	0V	16mV
3 3mV	69mV	0V	0V	3mV
4 -15.1V	-15.1V	-15.1V	-15.1V	2.2V
5 3mV	87mV	118mV	107mV	3mV
6 4mV	71mV	130mV	118mV	0.8V
7 -145mV	69mV	3mV	3mV	2.2V
8 15.1V	15.1V	15.1V	15.1V	3.3V

IC202	IC203
1 -15.1V	15 41mV
2 0V	16 43mV
3 12mV	17 250mV
4 -5mV	18 230mV
5 11mV	19 220mV
6 1mV	20 220mV
7 1mV	21 250mV
8 1mV	22 220mV
9 11mV	23 200mV
10 10mV	24 200mV
11 10mV	25 -5mV
12 10mV	26 190mV
13 41mV	27 200mV
14 -5mV	28 15.1V

IC203	
1 0V	9 230mV
2 4.9V	10 210mV
3 200mV	11 220mV
4 210mV	12 4.9V
5 4.9V	13 200mV
6 240mV	14 200mV
7 210mV	15 200mV
8 -15V	16 15V

IC501			
1 5mV	17 0.4V	33 1V	49 4.9V
2 5mV	18 0.4V	34 1V	50 2.4V
3 47mV	19 64mV	35 1V	51 2.5V
4 47mV	20 4.2V	36 1V	52 4.9V
5 47mV	21 4.2V	37 4.9V	53 4.8V
6 4.9V	22 4.2V	38 19mV	54 160mV
7 4.9V	23 4.2V	39 19mV	55 10mV
8 4.9V	24 4.2V	40 4.9V	56 55mV
9 4.9V	25 4.2V	41 100mV	57 55mV
10 4.9V	26 4.2V	42 110mV	58 4.9V
11 4.9V	27 1V	43 0.3V	59 160mV
12 0.4V	28 1V	44 160mV	60 4.2V
13 0.4V	29 1V	45 160mV	61 4.2V
14 0.4V	30 0.3V	46 4.9V	62 4.9V
15 0.4V	31 7mV	47 4.9V	63 4.9V
16 0.4V	32 8mV	48 4.9V	64 4.9V

IC503	MODE:UP/DN
1	0V
2	0V/5.2V
3	0.7V
4	0.8V
5	0.17V/1.7V
6	1.7V/0.17V
7	15V
8	15V
9	0.7V
10	5.2V/0V

IC901	
1	5.3V
2	11.9V
3	3.1V
4	12V
5	3.1V
6	3.1V
7	4.3V
8	4.1V
9	4.9V
10	3.1V
11	5.6V
12	3.1V
13	4.9V
14	4.3V

	E	C	B
Q101	12mV	19mV	0.6V
Q102	15.2V	15.1V	14.4V
Q203	-5mV	-5mV	-20mV
Q204	-20mV	-5mV	-5mV
Q501	4.9V	90mV	4.9V
Q502	4.9V	4.9V	63mV
Q503	4.9V	-3.5V	4.9V
Q504	4.9V	-3.5V	4.9V
Q505	5mV	-70mV	165mV
Q506	-60mV	4.7V	-40mV
Q507	4.9V	4.9V	160mV
Q508	5mV	4.9V	5V
Q509	4.7V	5mV	4.7V
Q510	4.9V	5mV	4.9V
Q511	5mV	4.7V	5mV
Q512	-40mV	-4.9V	-4.9V
Q555	5V	0V	4.9V
Q556	6mV	100mV	110mV
Q557	6mV	130mV	140mV
Q558	6mV	9mV	4.4V
Q581	6mV	110mV	120mV
Q701	0V	0V	(0.6V)
Q702	0V	0V	(0.6V)
Q703	0V	0V	(0.6V)
Q704	0V	0V	(0.6V)
Q705	-77mV	44V	-0.7V
	-76mV	44V	-0.7V
Q706	-70mV	43.8V	-0.7V
	-70mV	43.9V	-0.7V
Q707	-46.3V	-1.7V	-45.5V
Q708	-46.9V	-1.7V	-46.1V
Q709	44.8V	-24.5V	44.1V
Q710	45.3V	-24.6V	44.6V
Q711	44.7V	1.2V	44V
Q712	45.3V	1.2V	44.5V
Q713	-46.2V	-45.6V	-45.5V
Q714	-46.9V	-46.2V	-46.1V
Q715	-46.3V	-1.1V	-45.7V
Q716	-46.7V	-1.2V	-46.1V
Q717	-1.1V	1.2V	-0.5V
Q718	-1.2V	1.2V	0.6V
Q719	0.6V	47.5V	1.2V
Q720	0.6V	47.5V	1.2V
Q721	-0.6V	-47.6V	-1.1V
Q722	-0.6V	-47.2V	-1.2V
Q723	0.6V	47.4V	9mV
Q724	0.6V	47.5V	8mV
Q725	-0.6V	-47.6V	-9mV
Q726	-0.6V	-47.3V	10mV
Q727	0V	39.3V	9mV
Q728	0V	39.5V	9mV
Q729	40.1V	-1.2V	40V
Q730	40V	-0.5V	39.8V
Q732	15.1V	15V	14.3V
Q841	15V	0V	15V
Q901	3.3V	12V	4V

*():OFF

Electrical Parts List

Resistor : Carbon resistors under 1/4 watts are not mentioned in the parts list, please confirm them by schematic diagram.

Capacitor : μ F = microfarads, pF = picofarads

Abbreviations			
RES. = Resistor	CAP. = Capacitor		
C.F. = Carbon Film	ELY. = Electrolytic		
M.F. = Metal Film	CER. = Ceramic		
M.O. = Metal Oxide Film	MYL. = Mylar		
M.P. = Metal Plate	TAN. = Tantalum		
TR. = Transistor	POLY. = Polystyrol		
TRANS. = Transformer	PP. = Polypropylene		
CP. = Chip	PLT. = Polyethylene		
	PF. = Polyester Film		

Symbol No.	Part No.	Description	
Display P. C. Board			
Transistors			
Q555	92127317	DTA143ES	
Q556	92127318	DTC114ES	
Q557	92127318	DTC114ES	
Q558	92127318	DTC114ES	
Q581	92127318	DTC114ES	
Diodes			
D551	92119099	1SS131	
D552	92119099	1SS131	
D553	92119099	1SS131	
D554	92119099	1SS131	
D555	92119099	1SS131	
D556	92119099	1SS131	
D557	92119099	1SS131	
D558	92119099	1SS131	
D581	92119099	1SS131	
D582	92119099	1SS131	
Capacitors			
C551	90353181	CER.,	180pF
C552	90353181	CER.,	180pF
C553	90353181	CER.,	180pF
C554	90353181	CER.,	180pF
C555	90353181	CER.,	180pF
C556	90353181	CER.,	180pF
C557	90353181	CER.,	180pF
C558	90353181	CER.,	180pF
C562	90353181	CER.,	180pF
C563	90353181	CER.,	180pF
C564	90353181	CER.,	180pF
E566	90438100	ELY.,	10 μ F / 50V
C570	90353181	CER.,	180pF
C571	90353181	CER.,	180pF

Symbol No.	Part No.	Description	
LED's			
LD551	92119892	SLR-34DC3F (ORG)	
LD552	92119892	SLR-34DC3F (ORG)	
LD553	92119892	SLR-34DC3F (ORG)	
LD554	92119892	SLR-34DC3F (ORG)	
LD555	92119892	SLR-34DC3F (ORG)	
LD556	92119892	SLR-34DC3F (ORG)	
LD557	92119892	SLR-34DC3F (ORG)	
LD558	92119892	SLR-34DC3F (ORG)	
LD562	92119901	SLR-34VC3F (RED)	
LD563	92119901	SLR-34VC3F (RED)	
LD564	92119892	SLR-34DC3F (ORG)	
LD570	92119892	SLR-34DC3F (ORG)	
LD571	92119892	SLR-34DC3F (ORG)	
Switches			
S551	92190261	KEY (CD)	
S552	92190261	KEY (DAT)	
S553	92190261	KEY (TAPE)	
S554	92190261	KEY (TUNER)	
S555	92190261	KEY (PHONO)	
S556	92190261	KEY (AV)	
S557	92190261	KEY (LD)	
S558	92190261	KEY (VCR)	
S581	92190261	KEY (stand-by)	
S582	92190261	KEY (CD - synchro)	
Control P. C. Board			
IC's			
IC501	80519488	TMP47C660N	
IC502	92127258	MN1280-S	
IC503	92127222	LB1641	
Transistors			
Q501	92127317	DTA143ES	
Q502	92127317	DTA143ES	

Symbol No.	Part No.	Description	Symbol No.	Part No.	Description
Q503	92127317	DTA143ES	Resistor		
Q504	92127317	DTA143ES	R530	90520137	M.O., 10 ohm 2W
Q505	92127318	DTC114ES	Input P. C. Board		
Q506	92127318	DTC114ES	IC's		
Q507	92127317	DTA143ES	IC201	92127416	NJM4580L
Q508	92127318	DTC114ES	IC202	B0411630	TC9163N
Q509	92127317	DTA143ES	IC203	B0412150	TC9215P
Q510	92127317	DTA143ES	IC204	92127416	NJM4580L
Q511	92127318	DTC114ES	Transistors		
Q512	92127317	DTA143ES	Q203	92127335	2SD1302
Diodes			Q204	92127335	2SD1302
D501	92119099	1SS131	Diodes		
D502	92119099	1SS131	D203	92119099	1SS131
D503	92119099	1SS131	D204	92119099	1SS131
D504	92119099	1SS131	Capacitors		
D505	92119099	1SS131	C201	90353331	CER., 330pF
D506	92119099	1SS131	C202	90353331	CER., 330pF
D507	92119099	1SS131	C203	90458479	ELY., (B.P) 4.7 μ F/50V
D508	92119099	1SS131	C204	90458479	ELY., (B.P) 4.7 μ F/50V
D509	92119099	1SS131	C205	90353101	CER., 100pF
ZD501	92119799	Zener, HZS6.2EB1	C206	90353101	CER., 100pF
Crystal			E209	90416220	ELY., 22 μ F/25V
X501	92153586	CER., Lock 4MHz	E210	90416220	ELY., 22 μ F/25V
Capacitors			C211	90371153	MYL., 0.015 μ F
E501	90418229	ELY., 2.2 μ F/50V	C212	90371153	MYL., 0.015 μ F
C502	90321330	CER., 33pF	C213	90371563	MYL., 0.056 μ F
C503	90321330	CER., 33pF	C214	90371563	MYL., 0.056 μ F
C504	90353101	CER., 100pF	E219	90418109	ELY., 1 μ F/50V
C505	90328103	CER., 0.01 μ F			
E506	90416331	ELY., 330 μ F/25V			
C507	90328103	CER., 0.01 μ F			
E508	90410236	ELY., 470 μ F/50V			
E509	90418100	ELY., 10 μ F/50V			
C512	90371562	MYL., 5600pF			

Symbol No.	Part No.	Description	Symbol No.	Part No.	Description
E220	90418109	ELY., 1 μ F / 50V	Remote Sensor P. C. Board		
C221	90371472	MYL., 4700pF	Capacitor		
C222	90371472	MYL., 4700pF	C559	90328103	CER., 0.01 μ F
E223	90415330	ELY., 33 μ F / 16V	Volume P. C. Board		
E224	90415330	ELY., 33 μ F / 16V	Capacitors		
C233	90458229	ELY., (B.P) 2.2 μ F / 50V	E401	90418229	ELY., 2.2 μ F / 50V
C234	90458229	ELY., (B.P) 2.2 μ F / 50V	E402	90418229	ELY., 2.2 μ F / 50V
E237	90418229	ELY., 2.2 μ F / 50V	C403	90353181	CER., 180pF
E238	90418229	ELY., 2.2 μ F / 50V	Power Amp P. C. Board		
E241	90418229	ELY., 2.2 μ F / 50V	IC's		
E242	90418229	ELY., 2.2 μ F / 50V	IC121	92127254	NJM7815FA
E245	90418229	ELY., 2.2 μ F / 50V	IC122	92127255	NJM7915FA
E246	90418229	ELY., 2.2 μ F / 50V	IC131	92127254	NJM7815FA
E249	90418229	ELY., 2.2 μ F / 50V	IC701	92128492	μ PC1237HA
E250	90418229	ELY., 2.2 μ F / 50V	Transistors		
E253	90418229	ELY., 2.2 μ F / 50V	Q701	92127335	2SD1302
E254	90418229	ELY., 2.2 μ F / 50V	Q702	92127335	2SD1302
E257	90418229	ELY., 2.2 μ F / 50V	Q703	92127335	2SD1302
E258	90418229	ELY., 2.2 μ F / 50V	Q704	92127335	2SD1302
E261	90418229	ELY., 2.2 μ F / 50V	Q705	92127263	2SC3067
E262	90418229	ELY., 2.2 μ F / 50V	Q706	92127263	2SC3067
E265	90418229	ELY., 2.2 μ F / 50V	Q707	A6334820	2SC2705
E266	90418229	ELY., 2.2 μ F / 50V	Q708	A6334820	2SC2705
E269	90418229	ELY., 2.2 μ F / 50V	Q709	92127264	2SA1208
E270	90418229	ELY., 2.2 μ F / 50V	Q710	92127264	2SA1208
E271	90418229	ELY., 2.2 μ F / 50V	Q711	92127264	2SA1208
E272	90418229	ELY., 2.2 μ F / 50V	Q712	92127264	2SA1208
C273	90458229	ELY., (B.P) 2.2 μ F / 50V	Q713	92127265	2SC2910
C274	90458229	ELY., (B.P) 2.2 μ F / 50V	Q714	92127265	2SC2910
C277	90458229	ELY., (B.P) 2.2 μ F / 50V	Q715	92127265	2SC2910
C278	90458229	ELY., (B.P) 2.2 μ F / 50V			
E283	90418101	ELY., 100 μ F / 50V			
E284	90418101	ELY., 100 μ F / 50V			
C285	90353101	CER., 100pF			
C286	90353101	CER., 100pF			
E287	90416220	ELY., 22 μ F / 25V			
E288	90416220	ELY., 22 μ F / 25V			
E289	90416330	ELY., 33 μ F / 25V			
E290	90416330	ELY., 33 μ F / 25V			
E292	90415101	ELY., 100 μ F / 16V			

Symbol No.	Part No.	Description	Symbol No.	Part No.	Description
Q716	92127265	2SC2910	Coils / Relay		
Q717	A6361420	2SC3421	L701	92211498	1 μ H
Q718	A6361420	2SC3421	L702	92211498	1 μ H
Q719	A6361420	2SC3421	RL701	92148441	Relay, DH12D2
Q720	A6361420	2SC3421			
Q721	A6548170	2SA1358			
Q722	A6548170	2SA1358			
Q723	92127546	2SC3856			
Q724	92127546	2SC3856			
Q725	92127547	2SA1492			
Q726	92127547	2SA1492			
Q727	A6325849	2SC2240			
Q728	A6325849	2SC2240			
Q729	A6533649	2SA970			
Q730	A6533649	2SA970			
Q732	A6532946	2SA950			
Diodes			Capacitors		
D131	92115738	1N4003S	C121	90341223	CER., 0.022 μ F
D701	92119099	1SS131	C122	90341223	CER., 0.022 μ F
D702	92119099	1SS131	E123	90410196	ELY., 8200 μ F / 63V
D703	92119099	1SS131	E124	90410196	ELY., 8200 μ F / 63V
D704	92119099	1SS131	E125	90417471	ELY., 470 μ F / 35V
D707	92119099	1SS131	E126	90417471	ELY., 470 μ F / 35V
D708	92119099	1SS131	E127	90418221	ELY., 220 μ F / 50V
D709	92119099	1SS131	E128	90418221	ELY., 220 μ F / 50V
D710	92119099	1SS131	C131	90341223	CER., 0.022 μ F
D711	92119099	1SS131	E133	90417222	ELY., 2200 μ F / 35V
D712	92119099	1SS131	E134	90417471	ELY., 470 μ F / 35V
D713	92115738	1N4003S	E701	90410225	ELY., 10 μ F / 100V
D714	92115738	1N4003S	E702	90410225	ELY., 10 μ F / 100V
D715	92119099	1SS131	C703	90353221	CER., 220pF
D717	92119479	1SS130	C704	90353221	CER., 220pF
D718	92119479	1SS130	C707	90381222	P.P., 2200pF
D719	92119479	1SS130	C708	90381222	P.P., 2200pF
D720	92119479	1SS130	E713	90416470	ELY., 47 μ F / 25V
BD121	92119891	Bridge, RBV602	E714	90416470	ELY., 47 μ F / 25V
ZD703	92119785	Zener, HZS7C-2L	C715	90370069	M.F., 5pF
ZD704	92119785	Zener, HZS7C-2L	C716	90370069	M.F., 5pF
			C717	90370071	M.F., 33pF
			C718	90370071	M.F., 33pF
			C719	90370071	M.F., 33pF
			C720	90370071	M.F., 33pF
			C723	90371222	MYL., 2200pF
			E723	90410226	ELY., 220 μ F / 63V
			C724	90371222	MYL., 2200pF
			E724	90410226	ELY., 220 μ F / 63V
			E725	90410226	ELY., 220 μ F / 63V
			E726	90410226	ELY., 220 μ F / 63V
			C727	90371104	MYL., 0.1 μ F
			C728	90371104	MYL., 0.1 μ F
			C729	90370070	M.F., 22pF
			C730	90370070	M.F., 22pF
			C731	90370070	M.F., 22pF
			C732	90370070	M.F., 22pF
			C733	90371104	MYL., 0.1 μ F

Symbol No.	Part No.	Description
C734	90371104	MYL., 0.1 μ F
C735	90371104	MYL., 0.1 μ F
C736	90371104	MYL., 0.1 μ F
E737	90418100	ELY., 10 μ F/50V
E738	90418100	ELY., 10 μ F/50V
E739	90418100	ELY., 10 μ F/50V
E740	90418100	ELY., 10 μ F/50V
C741	90321470	CER., 47pF
C742	90321470	CER., 47pF
C743	90353101	CER., 100pF
C744	90353101	CER., 100pF
E745	90418109	ELY., 1 μ F/50V
E746	90418109	ELY., 1 μ F/50V
E747	90415221	ELY., 220 μ F/16V
E748	90415101	ELY., 100 μ F/16V
E749	90418479	ELY., 4.7 μ F/50V
C751	90371473	MYL., 0.047 μ F
C753	90371333	MYL., 0.033 μ F

Resistors

R121	90520180	M.O., 820 ohm 3W
R122	90520180	M.O., 820 ohm 3W
R759	90520145	M.F., 390 ohm 3W
R760	90520145	M.F., 390 ohm 3W
R765	90500001	M.P., 0.22 ohm 5W x 2
R766	90500001	M.P., 0.22 ohm 5W x 2
R769	90520137	M.F., 10 ohm 2W
R770	90520137	M.F., 10 ohm 2W
R803	90520141	M.F., 68 ohm 1W
R818	90520200	330 ohm 1W
VR701	92659176	Variable, 470 ohm
VR702	92659176	Variable, 470 ohm

Symbol No.	Part No.	Description
Supply P. C. Board		
IC's		
IC101	92127254	NJM7815FA
IC102	92127384	JBL1052CT
Transistors		
Q101	A6321251	2SC2120
Q102	A6532946	2SA950
Diodes		
D102	92115738	1N4003S
BD101	92119697	Bridge, W02-X
Relay		
RL001	92148442	DH12D1

Capacitors

C001	90340018	CER., 0.01 μ F
C002	90340018	CER., 0.01 μ F
C101	90341223	CER., 0.022 μ F
C102	90341223	CER., 0.022 μ F
E103	90417222	ELY., 2200 μ F/35V
E104	90418101	ELY., 100 μ F/50V
C105	90353102	CER., 1000pF
E105	90417471	ELY., 470 μ F/35V
E106	90418221	ELY., 220 μ F/50V

Resistors

R101	90520141	M.F., 68 ohm 1W
R104	90520158	M.F., 100 ohm 2W

Symbol No.	Part No.	Description	Symbol No.	Part No.	Description
Tone P. C. Board			Coil		
IC's			L901	92211472	100 μ H
IC401	92127416	NJM5480L			
IC402	92127416	NJM4580L			
Capacitors			Capacitors		
C421	90353101	CER., 100pF	E901	90414471	ELY., 470 μ F / 10V
C422	90353101	CER., 100pF	E902	90414471	ELY., 470 μ F / 10V
C423	90458229	ELY., (B.P) 2.2 μ F / 50V	E903	90414471	ELY., 470 μ F / 10V
C424	90458229	ELY., (B.P) 2.2 μ F / 50V	E904	90415471	ELY., 470 μ F / 16V
E427	90418229	ELY., 2.2 μ F / 50V	E905	90418479	ELY., 4.7 μ F / 50V
E428	90418229	ELY., 2.2 μ F / 50V	E906	90418479	ELY., 4.7 μ F / 50V
C429	90321470	CER., 47pF	E907	90418479	ELY., 4.7 μ F / 50V
C430	90321470	CER., 47pF	E908	90415331	ELY., 330 μ F / 16V
C431	90456220	ELY., (B.P) 22 μ F / 25V	E909	90415331	ELY., 330 μ F / 16V
C432	90456220	ELY., (B.P) 22 μ F / 25V	E910	90418479	ELY., 4.7 μ F / 50V
C433	90370072	M.F., 0.012 μ F	E911	90418330	ELY., 33 μ F / 50V
C434	90370072	M.F., 0.012 μ F	E912	90416220	ELY., 22 μ F / 25V
C435	90370073	M.F., 0.15 μ F	E913	90415102	ELY., 1000 μ F / 16V
C436	90370073	M.F., 0.15 μ F	C914	90351223	CER., 0.022 μ F
C437	90458479	ELY., (B.P) 4.7 μ F / 50V			
C438	90458479	ELY., (B.P) 4.7 μ F / 50V	Resistor		
C439	90353101	CER., 100pF	R915	90520141	M.F., 68 ohm 1W
C440	90353101	CER., 100pF			
E441	90418330	ELY., 33 μ F / 50V	Phone P. C. Board		
E442	90418330	ELY., 33 μ F / 50V	Resistors		
E443	90418330	ELY., 33 μ F / 50V	R831	90520144	M.F., 270 ohm 2W
E444	90418330	ELY., 33 μ F / 50V	R832	90520144	M.F., 270 ohm 2W
C445	90353101	CER., 100pF			
C446	90353101	CER., 100pF	Thermal Sensor P. C. Board		
Video P. C. Board			Transistor		
IC / Transistor			Q841	A6548170	2SA1358
IC901	92127257	LA7951			
Q901	A6317465	Transistor, 2SC1815			

Symbol No.	Part No.	Description	Symbol No.	Part No.	Description
Miscellaneous					
F001	92144520	Fuse, 4A-250V			
F002	92144518	Fuse, 2.5A-250V			
F101	92144511	Fuse, 500mA-250V			
F111	92144514	Fuse, 1A-250V			
IC551	92127260	IC, GP1U501X			
JK201	92198550	Jack, US2P (PHONO)			
JK202	92198553	Jack, US4P (CD / TUNER)			
JK203	92198553	Jack, US4P (DAT)			
JK204	92198553	Jack, US4P (TAPE)			
JK205	92198553	Jack, US4P (VCR)			
JK206	92198553	Jack, US4P (AV)			
JK207	92198553	Jack, US4P (ADAPTER)			
JK821	92252739	Speaker Terminal (8P)			
JK822	92198547	Jack, 2P (BUS LINE)			
JK831	92198562	Jack, (Head-Phone)			
JK901	92198551	Jack, US3P (AV / LD / VCR, PLAY)			
JK902	92198549	Jack, US2P (TV / VCR, REC)			
S401	92190329	Switch, SPUN21 (CD straight)			
S402	92190329	Switch, SPUN21 (mono)			
S821	92190328	Switch, SPUN24 (speaker A)			
S822	92190328	Switch, SPUN24 (speaker B)			
VR401	92627204	Volume, 100K ohm			
M401					
LD401					
VR402	92620250	Resistor, Variable 250K ohm (BALANCE)			
VR403	92622238	Resistor, Variable 10K ohm (BASS)			
VR404	92622238	Resistor, Variable 10K ohm (TREBLE)			
T001	92225715	TRANS., Power			
T002	92225714	TRANS., Power			
S001	92190317	Switch, Voltage			
P001	92176802	Plug, AC Cord			
P004	92169483	Outlet, AC			

Cabinet Assembly Parts List

NOTE : The parts without parts list are not supplied.

Symbol No.	Index	Part No.	Description	Symbol No.	Index	Part No.	Description
○	1	4-G 96213907	Assy., Front Panel		37	4-C 92707610	Screw, Tapping (M4×6)4
x	1	4-G 96213907	Assy., Front Panel		38	92755997	Cord, Clamp
△	1	4-G 90017647	Assy., Front Panel		40	4-E 92753878	Support, P.C.Board
□	1	4-G 90017647	Assy., Front Panel		41	4-F 92838605	Shield, Plate
○	2	3-B 92837945	Cover, Top		42	3-G 92838610	Shield, Master
x	2	3-B 92837945	Cover, Top		43	3-E 92755623	Lug, Clamp
△	2	3-B 92837947	Cover, Top		44	4-E 92184188	Lug
□	2	3-B 92837947	Cover, Top	○	50	4-G 92707446	Screw, Bind (M3×6)
○	3	1-D 92838596	Cover, Rear	x	50	4-G 92707446	Screw, Bind (M3×6)
x	3	1-D 92838616	Cover, Rear	△	50	4-G 92707455	Screw, Bind (M3×6)
△	3	1-D 92838596	Cover, Rear	□	50	4-G 92707455	Screw, Bind (M3×6)
□	3	1-D 92838616	Cover, Rear				
○	4	90874833	Button, Push				
x	4	90874833	Button, Push				
△	4	90874880	Button, Push				
□	4	90874880	Button, Push				
	6	90842690	Foot				
	7	92755955	Support, P.C.Board				
	11	92165047	Fuse, Holder				
	12	5-C 92758368	Cover, Capacitor				
	13	92708539	Screw, MCH (M3×6)				
	14	3-D 92766893	Cover, SW				
	15	92766894	Cushion, Cover				
○	16	5-G 90874835	Knob, Main				
x	16	5-G 90874835	Knob, Main				
△	16	5-G 90874881	Knob, Main				
□	16	5-G 90874881	Knob, Main				
○	17	5-G 90874837	Knob, Tone				
x	17	5-G 90874837	Knob, Tone				
△	17	5-G 90874878	Knob, Tone				
□	17	5-G 90874878	Knob, Tone				
	19	2-C 95844322	Cord, Bush				
	20	92709561	Screw, MCH (M3×10)				
	21	1-C 92252725	Terminal, GND				
	27	1-C 92187777	Plug, Jumper				
	28	92707842	Screw, Tapping (M3×8)				
	29	92707885	Screw, Tapping (M3×8)				
	30	92707979	Screw, Tapping (M2.6×8)				
	31	92709579	Screw, MCH (M3×8)				
	33	92708022	Screw, Pan (M3×6)				
	34	92707798	Screw, Pan (M3×10)				
	35	92707446	Screw, Bind (M3×6)				
	36	92707185	Screw, Bind (M4×8)				

Notes : ○ : For Black Type (Without Safety Regulation Version) [EK],
 x : For Black Type (With Safety Regulation Version) [AD],
 △ : For Champagne Gold Type (Without Safety Regulation Version) [EK],
 □ : For Champagne Gold Type (With Safety Regulation Version) [AD], Others : Common.

Packing Assembly Parts List

Symbol No.	Part No.	Description	Symbol No.	Part No.	Description
○	101	92929808			Carton, Packing
×	101	92929850			Carton, Packing
△	101	92929847			Carton, Packing
□	101	92929847			Carton, Packing
	102	92938622			Cushion (L)
	103	92938623			Cushion (R)
	104	92947082			Protector
	105	92944003			Poly., Bag
	106-1	68P21552W45			Owner's, Manual
	106-2	92120254			Remote Control Unit
	106-3	92101314			Battery

Notes : ○ : For Black Type (Without Safety Regulation Version) [EK],
 × : For Black Type (With Safety Regulation Version) [AD],
 △ : For Champagne Gold Type (Without Safety Regulation Version) [EK],
 □ : For Champagne Gold Type (With Safety Regulation Version) [AD], Others : Common.

Packing Method View

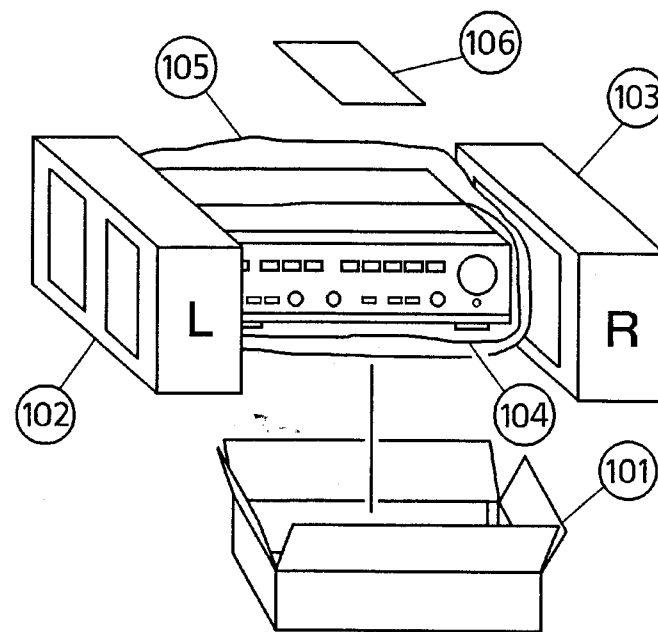

Semi - Conductor Lead Identifications

NJM7815FA : IC101, 121, 131

JBL1052CT : IC102

NJM7915FA : IC122

NJM4580L : IC201, 204, 401, 402

TC9163N : IC202

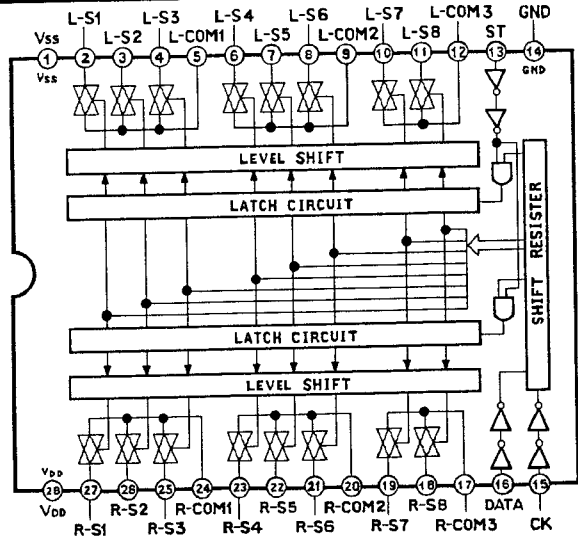
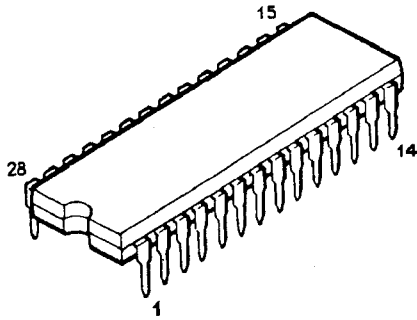

TC9215P : IC203

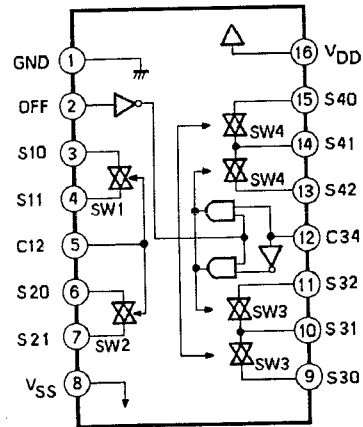
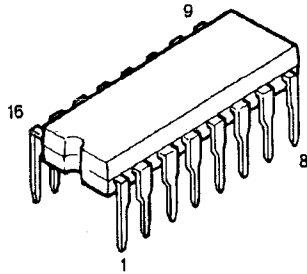

TMP47C660N : IC501

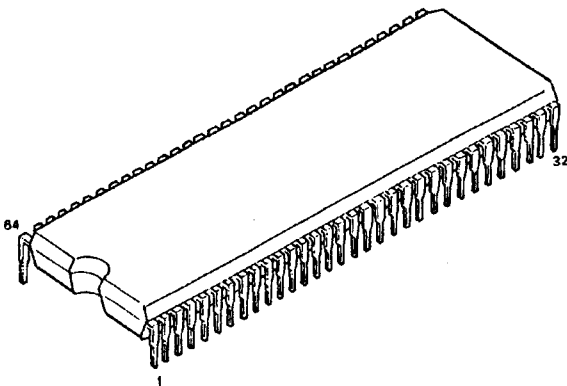

PIN NO.	CORD ADDRESS	I/O	PIN NO.	CORD ADDRESS	I/O	PIN NO.	CORD ADDRESS	I/O
1	VA REF	—	23	AM MUTE	0	45	K0	0
2	VA SS	—	24	SELE MUTE	0	46	K1	0
3	DTA	0	25	NC	—	47	K2	0
4	CLK	0	26	NC	—	48	K3	0
5	STB	0	27	CD	0	49	RST	0
6	C34	0	28	DAT	0	50	X IN	I
7	OFF	0	29	TA	0	51	X OUT	0
8	C12	0	30	TU	0	52	HOLD	—
9	V-a	0	31	TEST	—	53	REMO	I
10	V-b	0	32	VSS	—	54	NC	—
11	DAT MUTE	0	33	PHO (LED)	0	55	S.I	I
12	NC	—	34	AV (LED)	0	56	S.O	0
13	NC	—	35	LD (LED)	0	57	VOL. (LED)	0
14	NC	—	36	VCR (LED)	0	58	SYNC. (LED)	0
15	NC	—	37	NC	—	59	NC	—
16	NC	—	38	NC	—	60	VOL. UP	0
17	NC	—	39	NC	—	61	VOL. DOWN	0
18	NC	—	40	NC	—	62	NC	—
19	PDW	0	41	D0	I	63	VDD	—
20	NC	—	42	D1	I	64	VDD	—
21	NC	—	43	D2	I			
22	NC	—	44	D3	I			

MN1280-S : IC502

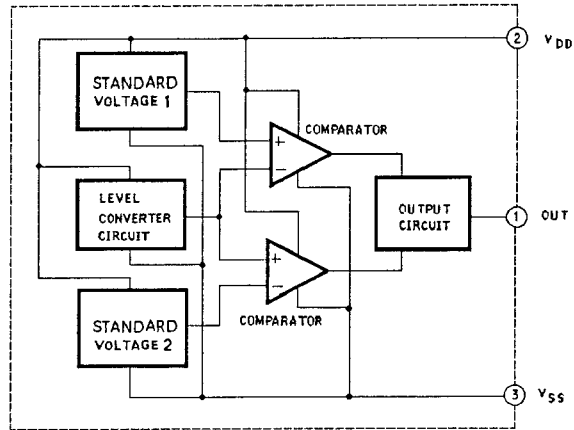
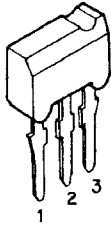

LB1641 : IC503

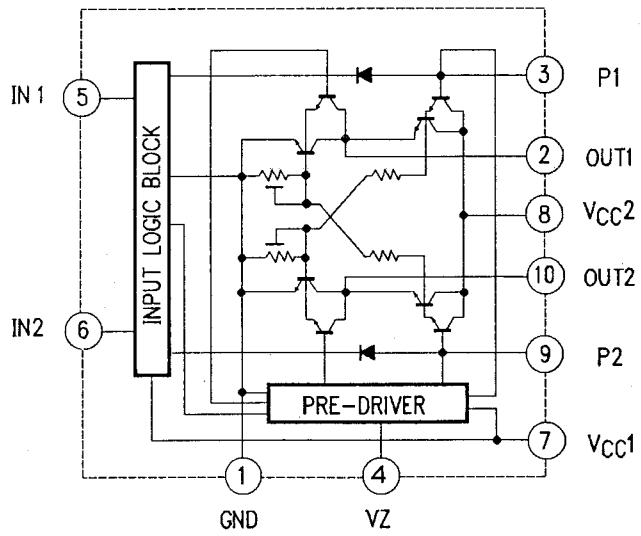
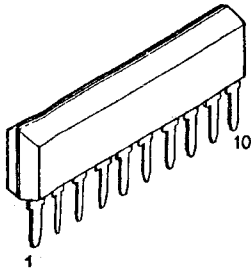

GP1U501X : IC551

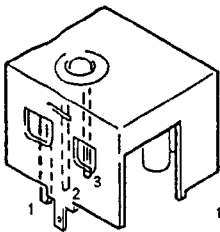

- 1. Vcc
- 2. Vout
- 3. GND

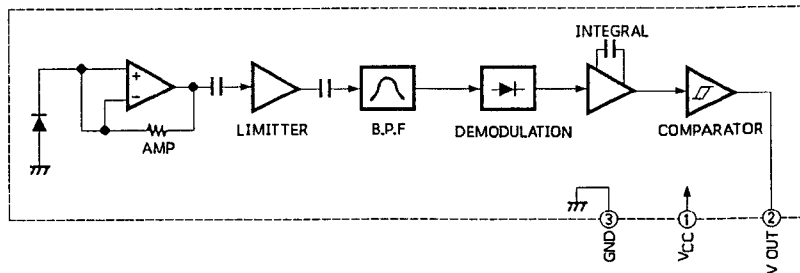

μ PC1237HA : IC701

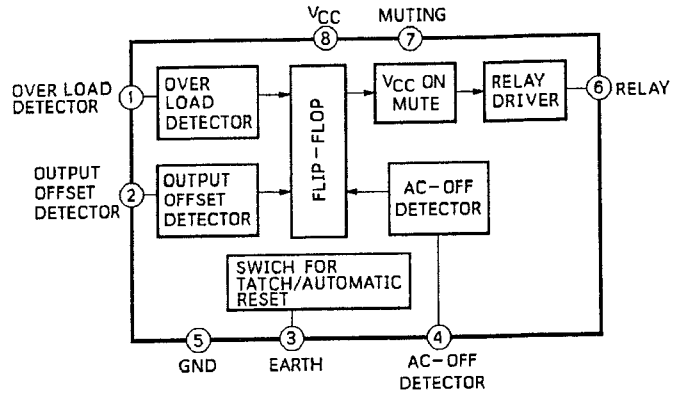
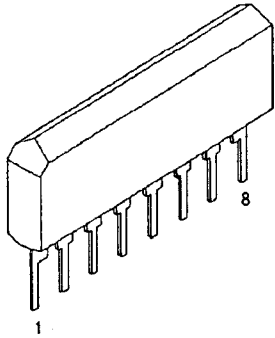

LA7951 : IC901

